

Figure 1

SPECIFICATIONS

Electrical Requirements

- Input** 24 VDC @ 2 amps
- Enclosure Rating** IP 6K9K - Protected from water sprayed in all directions.
- Alarm Time** 30 minutes
- Interval between cycles**..... 4 minutes minimum
60 minutes maximum
- Pump Output** 0.171 cu. in./min (2.8 cm/min) with installed 6 mm element
- Outlet Connection** 1/8" NPT (female)
- Maximum Recommended**
 - Operating Pressure** 3600 psi (248 bar)
 - Reservoir Capacity** 244 cu. in. (4000 cc)
 - Lubricant**..... Greases up to NLGI grade 2 (depending on the operating temperature and type of lubricant)
- Temperature Range**..... - 13° F (-25°C) to +158° F (+70°C)
- Pressure Relief Valve** 4000 psi +/- 250 psi (276 bar) +/- (17 bar)

DESCRIPTION

The chassis lube pump is electrically operated and used in a progressive type centralized lubrication system. The pump incorporates a low-level sensor which will cause a LED light on the circuit board to blink if a low-level condition occurs. This signal may also be sent to an optional dash mounted light if desired.

The frequency of the pump's lubrication cycles is controlled by the internal microprocessor. A proximity switch, installed on one of the system's secondary divider valves must be utilized to signal completion of a lubrication cycle. If a signal is not received within 30 minutes of a fault signal, as described above, will also occur. This feature is used to monitor the pump's operation and to detect any blocked or broken supply lines.

The pump consists of a pump housing, electric gear motor, the microprocessor and a plastic reservoir with stirring paddle. The high operating pressure capability allows the pump to supply lubricant up to NLGI #2 grease.

MOUNTING THE PUMP

Select an easily accessible place of installation which allows access to the timer and lubricant reservoir filler fitting. The pump must be mounted vertically on an even surface by means of three bolts.

TO FILL RESERVOIR

Fill the reservoir through the grease fitting located at the base of the reservoir. Reservoir can be filled using a hand operated grease pump, a pneumatic pump or electric transfer pump.

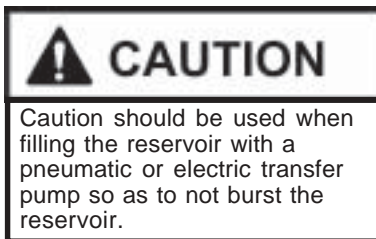

Refill reservoir when grease reaches "MIN" mark located on the reservoir. Fill the reservoir up to the "MAX" mark located on the reservoir.

TO PRIME SYSTEM

Pump & Supply Line: After reservoir has been filled with recommended lubricant, loosen the supply line fitting. Operate the pump until lubricant flows from outlet, then tighten fitting.

Feed Lines: Pre-fill each feed line with lubricant before connecting to outlet of divider valve and bearing.

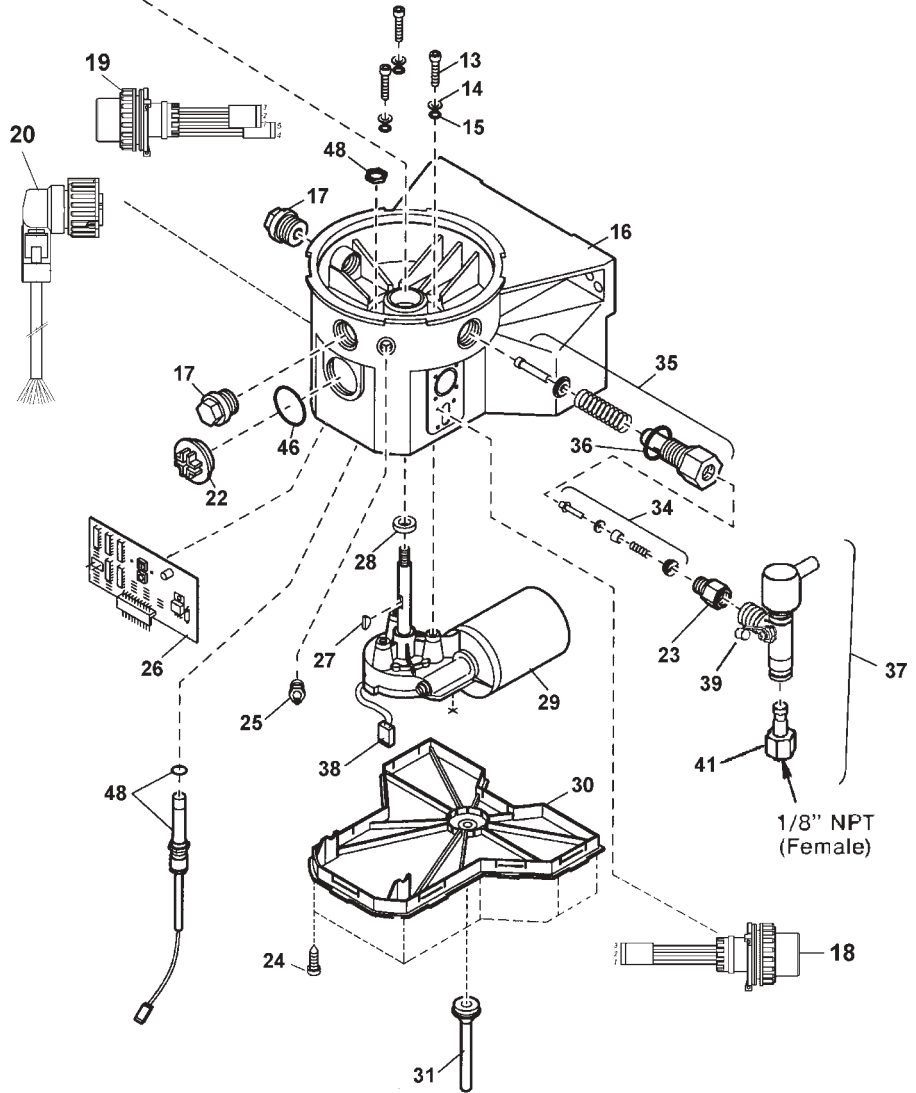
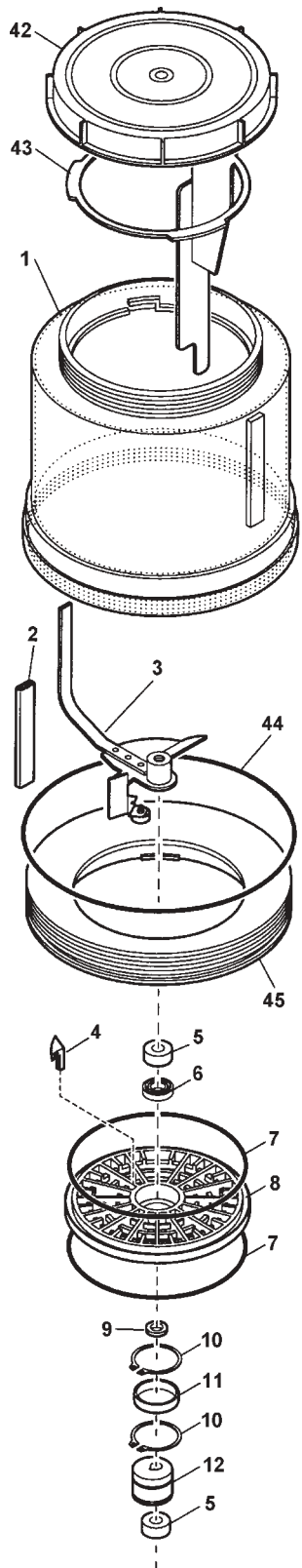

Figure 2

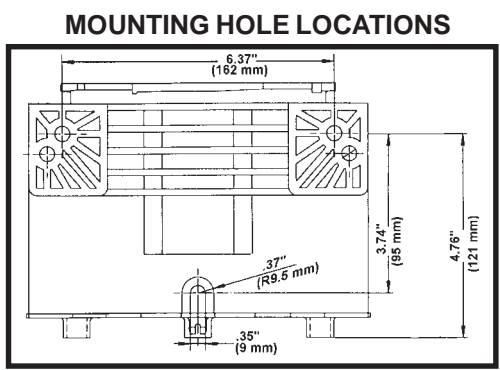

Figure 3

PARTS LIST

ITEM NO.	DESCRIPTION	QTY.	PART NUMBER /KIT NUMBER
1	Reservoir	1	247673
2	Hose	1	247676
3	Stirring paddle	1	544-31994-1©
4	Control Cam	1	249903
5	Bearing ring	2	part of kit 246434
6	Bearing	1	part of kit 246434
7	O-ring	2	246424
8	Intermediate plate	1	246425
9	Shim	1	part of kit 246434
10	Snap ring	2	part of kit 246434
11	Inner ring	1	part of kit 246434
12	Eccentric cam	1	246427
13	Screw	3	part of kit 246436
14	Washer	3	part of kit 246436
15	O-ring	3	part of kits 246436 & 246437
16	Pump housing	1	246426
17	Closure plug	2	246422
18	3 wire internal plug	1	273483
19	5 wire internal plug	1	273484
20	5 wire power cord/plug	4	273485
22	Sealing plug	1	246423
23	Nipple	1	226-14105-5
24	Screw	10	206-13796-7
25	Grease fitting	1	5050
26	Microprocessor	1	249905
27	Woodruff key	1	part of kit 246436
28	Radial seal	1	part of kit 246436 & 246437
29	24 VDC motor	1	part of kit 246436
30	Housing cover	1	246421
31	Hose	1	not sold
33	Proximity switch	1	See below
34	Check valve	1	part of kit 600-26876-2
35	Pump element	1	part of kit 600-26876-2
36	Gasket	1	part of kit 600-26876-2
37	Pressure relief assembly	1	270864
38	Plug for motor	1	part of kit 246436
39	Grease cap	1	242125
41	Adapter for relief assembly	1	304-19614-1
42	Lid	1	247671
43	Fixed paddle	1	247664
44	O-ring	1	247677
45	Adapter	1	247678
46	O-ring	1	219-14138-2
48	Magnetic Switch Kit	1	249904

Proximity Switches

The following proximity switches for black colored blocks only:

273486 3-meter (9.8 ft) cable length

273487 7-meter (23.0 ft) cable length



Figure 4 - Proximity Switch

SERVICE PARTS/KITS

Part No.	Qty.	Description	Item No.
5050	1	Grease fitting	25
242125	1	Grease cap	39
246421	1	Housing cover	30
246422	1	Closure plug	17
246423	1	Sealing plug	22
246424	2	O-ring	7
246425	1	Intermediate plate	8
246426	1	Pump housing	16
246427	1	Eccentric cam	12
246434		Bearing & Seal Kit contains:	
	2	Bearing ring	5
	1	Bearing	6
	1	Shim	9
	2	Snap ring	10
246436		24 VDC Motor Kit contains:	
	3	Screw	13
	3	Washer	14
	3	O-ring	15
	1	Woodruff key	27
	1	Radial seal	28
246437		Housing Seal Kit contains:	
	3	O-ring	15
	1	Radial seal	28
247664	1	Fixed paddle	43
247671	1	Lid	42
247673	1	Reservoir	1
247676	1	Hose	2
247677	1	O-ring	44
247678	1	Adapter	45
249903	1	Cam	4
249904	1	Magnetic Switch Kit	48
249905	1	Microprocessor	26
270864	1	Pressure relief assembly	37
273483	1	3 wire internal plug	18
273484	1	5 wire internal plug	19
273485	1	5 wire power cord/plug	20
219-14138-2	1	O-ring	46
226-14105-5	1	Nipple	23
206-13796-7	10	Screw	24
304-19614-1	1	Adapter for relief assembly	41
544-31994-1	1	Stirring paddle	3
600-26876-2		Pump Element Assembly contains:	
	1	Check valve	34
	1	Pump element	35
	1	Gasket	36

©

When replacing service part 249905 microprocessor circuit board check to see that the jumpers in the new board are positioned the same as the old board. See illustration below showing location of the five jumpers.

©

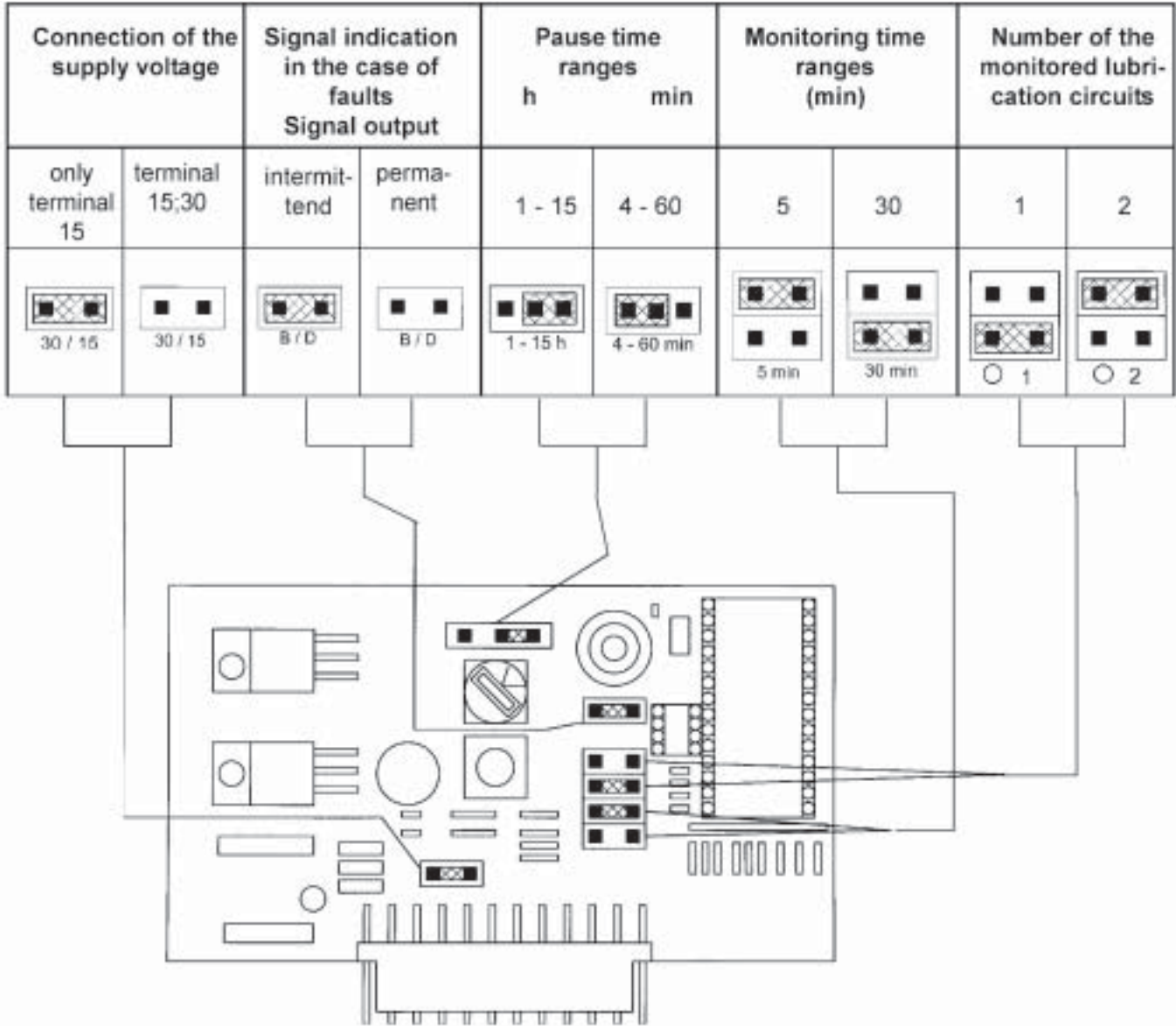

© Indicates change

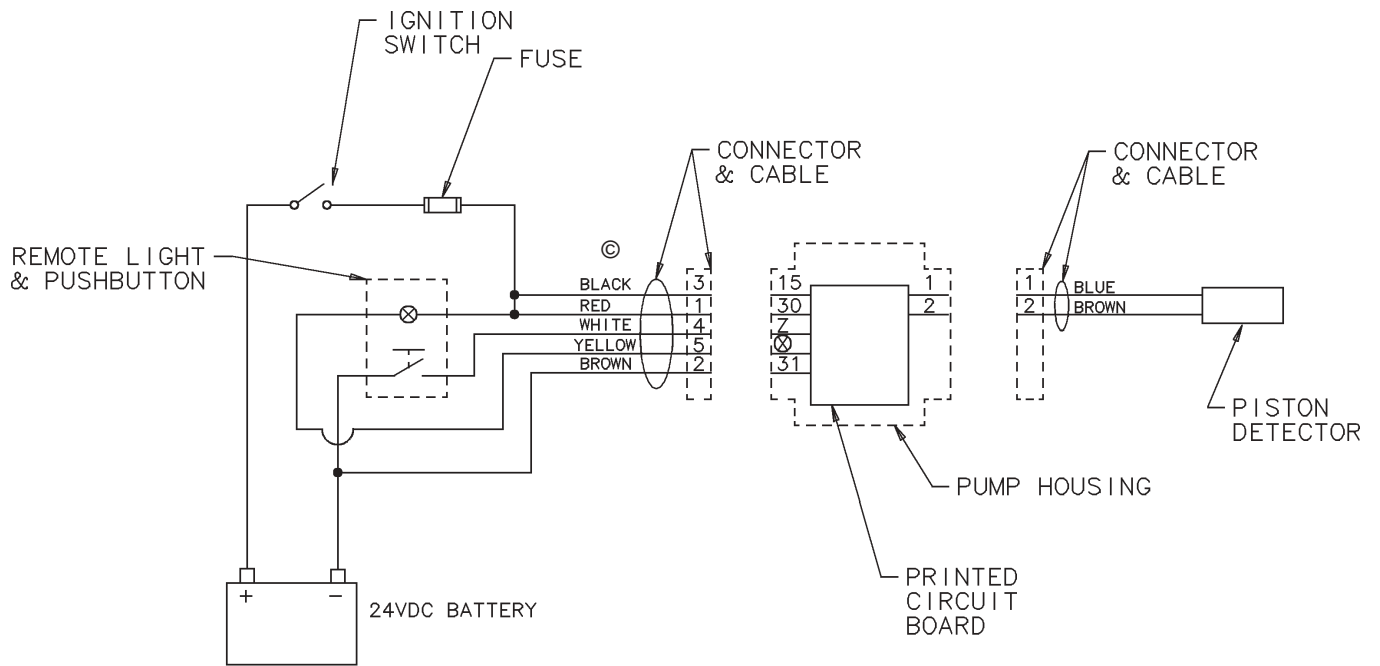

WIRING DIAGRAM FOR POWER AND REMOTE LIGHTED MANUAL LUBE SWITCH

SYSTEM ACCESSORIES

DESCRIPTION	PART NO.
PUSHBUTTON & LIGHT (24 VDC)	241484
8 AMP FUSE	241052
FUSE HOLDER	241053

Figure 5

© Indicates change

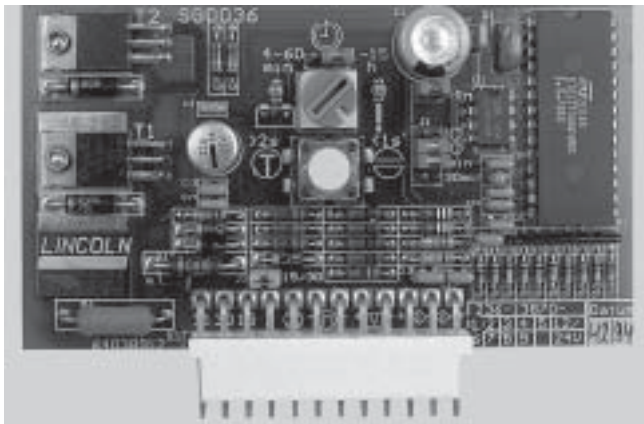

Fig. 6 - Printed circuit board 236-13870-1

- The printed circuit board automatically controls the sequence of the pause and operating times of the 203 central lubrication pump as a function of the vehicle or machine working hours t_B (Fig. 7).
- The sequence of the pause and operating times is activated when the machine contact or ignition switch is switched on.
- A lubrication cycle consists of one pause time and one operating time. Once the pause time has elapsed, the operating time starts to run. This lubrication cycle is repeated permanently after the machine or vehicle has been put into operation. Refer to Fig. 7.
- During the operating time the pump element dispenses the lubricant to the lubrication points via progressive metering devices.

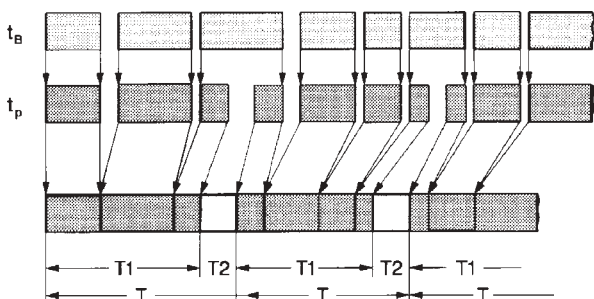

Fig. 7 - Time sequence diagram

t_B - Working hours
 t_P - Various pause times
 T - Lubrication cycle
 T_1 - Stored pause times
 T_2 - Operating times

Pause time

- The pause time
 - determines the frequency of the lubrication cycles within a working cycle;
 - is started and stopped via the machine contact or ignition switch;
 - is adjustable.
- When the machine contact or the ignition switch is switched off, the pause times which have already elapsed as well as the momentary operating conditions (faults) are stored and added up by an electronic memory (EEPROM) until the time which has been set on the blue rotary switch is reached.
- After the machine contact or ignition switch is switched on again, the printed circuit board operates from the point where it had been interrupted.

- If the setting is modified within the pause time, the printed circuit board takes over the new value only at the end of the operating time.
- The pause time setting may be different for each application. It must be adjusted in accordance with the respective lubrication cycles. Also refer to "To set the pause time".

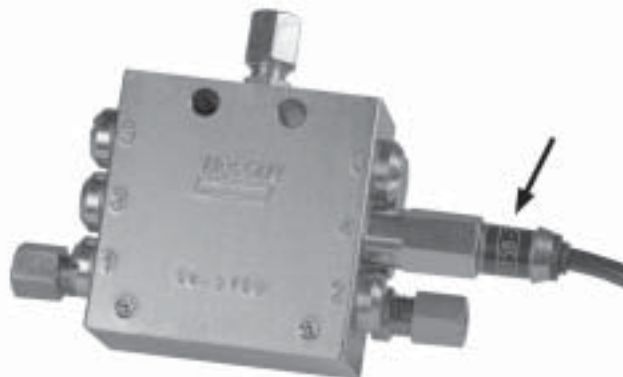

Fig. 8 - Proximity Switch

Operating time

- A **proximity switch** (initiator) which has been installed on a metering device instead of a piston closure plug monitors and brings the pump operating time to a close after all the pistons of this metering device have dispensed their lubricant quantity.
- The operating time depends on the system's lubricant requirement and on the location of the proximity switch (either on the main metering device or on the secondary metering device).
- During the operating time, the **signal lamp is permanently lit**.

Monitoring time

- A fixed **monitoring time** of maximum 30 minutes.

Note: Normally, the monitoring time ends at the same time as the operating time.

- If there is **no switching off signal** from the proximity switch to the printed circuit board within 30 minutes, a **fault signal** will occur. The signal lamp flashes with the corresponding flashing frequency. See "Fault indication".

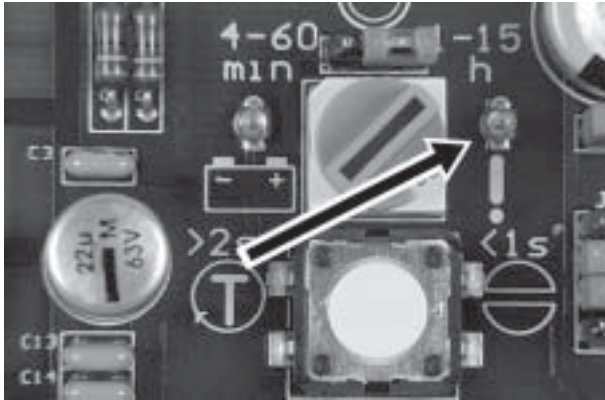

Fig. 9 - LED for the monitoring time or fault indication

Functional check

- Each time the machine contact (external contact) or the driving switch is switched on, a functional check of the drive motor and signal lamp takes place automatically.
- During the functional check the motor is switched on for **0.1 second** (the stirring paddle slightly rotates) and the signal lamp lights up for **2 seconds**.
- If there is a fault, the signal lamp **flashes**. See "Fault Indication".

Note: LED display Fig.9 indicates the same operating state as the signal lamp.

Functions of the Pushbutton and Signal Lamp

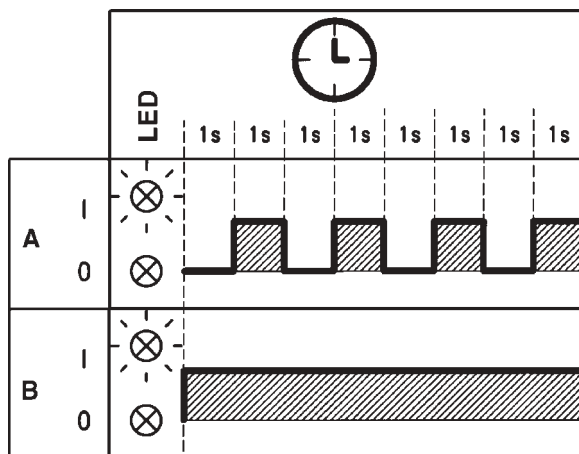

Fig. 10 - Indicated operating states

A - Fault indication

B - Indication of operation or acknowledged fault

Pushbutton (Fig. 11)

- The following functions can be performed with the pushbutton:
 - triggering an additional lubrication cycle - Press pushbutton for over 2 seconds (> 2 s)
 - fault acknowledgement < 1 s
 - in the case of a fault, switching on pump again by pressing pushbutton (> 2 seconds)

Note: It is also possible to acknowledge any fault or to trigger an additional lubrication cycle via pushbutton 4 of the printed circuit board (Fig. 14).

Signal lamp

- The signal lamp or the LED fig. 14 indicates the operating state of the centralized lubrication system.
- The faults are indicated by different flashing frequencies of the signal lamp or the LED fig. 14. See "Fault Indication".

To acknowledge a Fault



Fig. 11 - To acknowledge a fault

- When the pushbutton is pressed briefly (< 1 second) the fault is acknowledged, i.e. the lamp stops flashing and is permanently lit.

Note: Any acknowledged fault remains stored even after the driving switch or machine contact has been switched off. Upon switching on again, the signal lamp flashes again in accordance with the fault.

To Remedy to a Fault

- * In the case of a malfunctioning, check the central lubrication pump and the connected system for faults.
- * Eliminate the cause of the fault.
- * Switch on the pump again by triggering an additional lubrication cycle. For this, press the pushbutton **> 2 seconds**.
- When the fault is eliminated, the signal lamp will extinguish **at the end of the lubrication cycle**.

Important: If there has been any fault, the pump will not start automatically after the elimination of that fault. It must be switched on, i.e. an additional lubrication cycle must be triggered. See "To trigger an additional lubrication cycle".

*Note: It is also possible to acknowledge/reset a fault or trigger an additional lubrication cycle by means of the pushbutton on the printed circuit board (Fig. 20). For this, press it < 1 second and > 2 seconds. **Condition: The machine contact or driving switch must be switched on.***

Time Setting



Fig. 12 - The cover to the printed circuit board has been removed

* To set the pause time, remove the cover on the pump housing.

Important: After having set the pause time, screw the cover on the pump housing again.

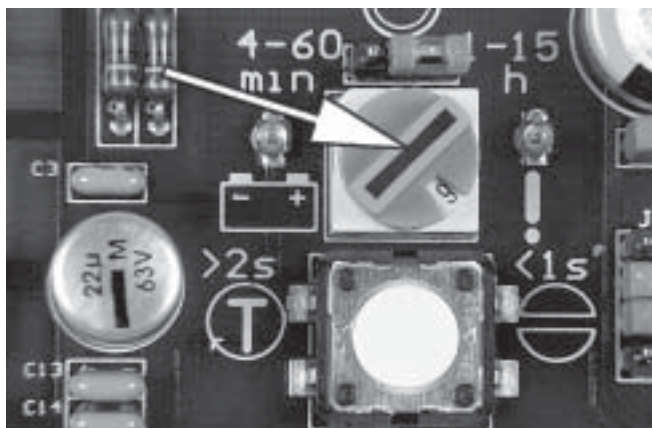

Fig. 13 - Rotary switch - Pause time

To set the pause time

The pause time can be adjusted to 15 settings by means of the **blue rotary switch**.

Operational Test /To Trigger an Additional Lubrication Cycle

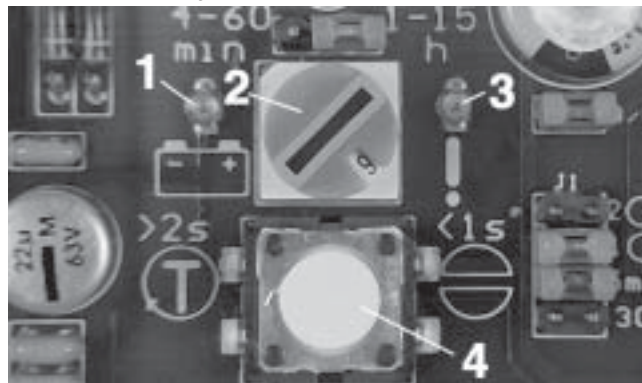

Fig. 14 - LED of the printed circuit board

- 1 - LED, left-hand Power supply
- 2 - Rotary switch "pause time"
- 3 - LED, right-hand, Indication of operation
- 4 - Pushbutton for additional lubrication cycle

- To check the function of the pump it is possible to perform an operational test.

- * If necessary, switch on the battery voltage
- * Switch on the driving switch

- To check whether power is applied to the printed circuit board, observe whether the left-hand LED 1, Fig. 20, is lit.

- * Press the pushbutton (**> 2 seconds**) for triggering an additional lubrication (illuminated pushbutton, Fig. 16, or pushbutton on the switch cabinet) until the right-hand LED 3 lights up.

- The right-hand LED indicates the following functions:
 - operating time
 - monitoring time (in normal cases it is as long as the operating time, in the case of a fault: 30 minutes)
 - faults

- When an additional lubrication cycle has been triggered, a shorter pause time occurs, followed by a normal lubrication cycle.

- Additional lubrication cycles can be triggered at any time.

Switch position	1	2	3	4	5	6	7	8	9	A	B	C	D	E	F
Minutes	4	8	12	16	20	24	28	32	36	40	44	48	52	56	60

Note: The 0 position corresponds to the shortest time, see pos. 1.

Fault Indication

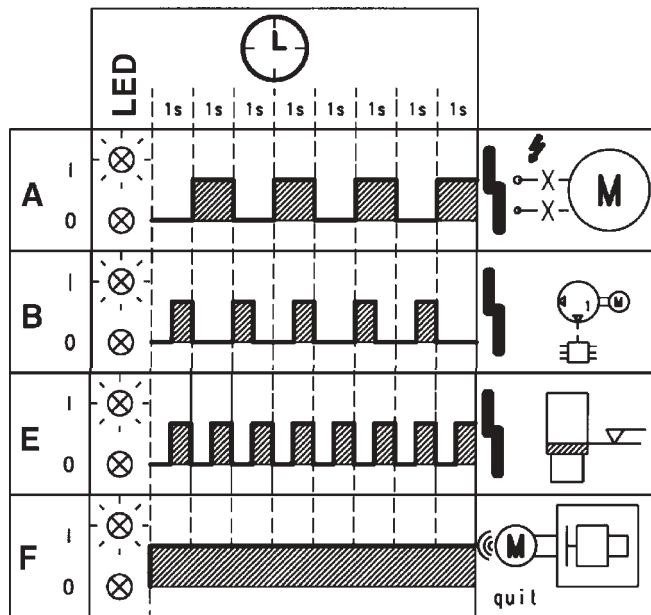

Fig. 15 - Flashing frequencies in the case of malfunctions

- A - Drive motor defective
- B - Lubrication circuit 1 malfunctioning
- E - In the case of low-level control: reservoir empty
- F - Fault acknowledged (maintained lightening)

Drive motor defective

If the motor does not run when the driving switch or machine contact is switched on or if the feed line to the motor is damaged, the signal lamp flashes after 2 seconds as follows:

A 1 second - "ON" - 1 second - "OFF"

Malfunctions

such as

- blocked lubrication point (s)
- blocked metering devices (s)
- interruption in the main line leading to the metering device equipped with a proximity switch
- air in system
- reservoir empty

are indicated as described under B.

The above mentioned faults cause the pistons in the monitored metering device to stop. The signal lamp indicates the respective fault signal with the following flashing frequencies:

Lubrication circuit 1 malfunctioning

B 0.5 second - "ON" - 1 second - "OFF"

Low-level control

The signal lamp is flashing with the following frequency:

Reservoir empty

E 0.5 second - "ON" - 0.5 second - "OFF"

Note: The low-level signal is converted into a flashing signal with the a.m. frequency only after 6 motor revolutions.

- In the case of a malfunction the proximity switch (initiator) can no longer record the piston movements and therefore, it cannot switch off the pump.
- Due to the monitoring time which runs in parallel to the operating time, the printed circuit board switches off the pump at the end of the monitoring time.
- A fault signal occurs.
- The signal lamp is flashing.
- The pump no longer starts automatically. See "To Remedy to a Fault"

Troubleshooting

Note: The pump operation can be checked from the outside by observing whether the stirring paddle is rotating (e.g. by triggering an additional lubrication),

whether the LED on the printed circuit board are lit or the signal lamp of the illuminated pushbutton/switch cabinet is lit.

• Fault: The pump motor does not run	
• Cause:	• Remedy:
<ul style="list-style-type: none"> • Voltage supply interrupted. • Voltage supply to the printed-circuit board is interrupted. • Printed circuit board defective. 	<ul style="list-style-type: none"> • Check the voltage supply to the pump. If necessary, eliminate the cause of the fault. • Check the line leading from the pump plug to the printed circuit board. • If the voltage is applied, the left-hand LED is lit. • Replace the printed circuit board.
• Fault: The pump motor runs permanently (30 minutes)- Duration of the monitoring time	
• Cause:	• Remedy:
<ul style="list-style-type: none"> • Proximity Switch (initiator) defective. • Cable connection of the proximity switch to the pump interrupted. • Printed circuit board defective. 	<ul style="list-style-type: none"> • Disconnect the main line leading to the monitored metering device. • Unscrew the proximity switch and check it. For this, insert metallic pin into the borehole of the detector. Let it there over 2 seconds and then remove it. If the pump is not switched off afterwards, check the cable connections to the pump. If necessary, replace the proximity switch along with the connector. • Check the cable connections to the pump. If necessary, replace the proximity switch with the connector. • Replace the printed circuit board

Americas:
One Lincoln Way
St. Louis, MO 63120-1578
USA
Phone +1.314.679.4200
Fax +1.800.424.5359

Europe/Africa:
Heinrich-Hertz-Str 2-8
D-69183 Walldorf
Germany
Phone +49.6227.33.0
Fax +49.6227.33.259

Asia/Pacific:
25 Int'l Business Park
#01-65 German Centre
Singapore 609916
Phone +65.562.7960
Fax +65.562.9967

© Copyright 2004
Printed in USA

Web site:
www.lincolnindustrial.com