

# QuickData®

## Pump 233 with Data Logger



4354a01

Subject to change without notice

Requesting a service page in French, Italian/Spanish language, see page 35  
Ordenar manual en español: página 35  
Pour la commande de ce manuel en français, voir page 35  
Ordinazione della documentazione italiana, vedi pagina 35

810-55293-1

## Fields of Application of the QUICKDATA Progressive Central Lubrication Pumps

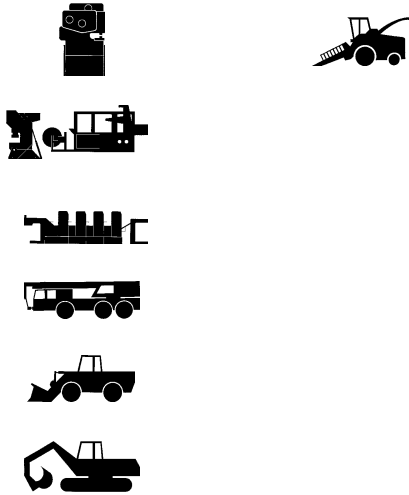
Industry - Machines - Commercial Vehicles - Building Machinery - Agricultural Machines	Pump Type
	<p><b>Pump</b> : QUICKDATA 233</p> <p><b>Reservoir</b> : 2 l -2XL*,2XLFL*, 2XLBO*            4 l -4XLBO*            8 l - 8XLBO*</p> <p>* Filling from the bottom            4l, 8l with lockable reservoir lid (option)</p> <p><b>Low-level control (option) for all reservoir sizes</b></p> <p><b>Control</b> : Integrated control unit with metering device monitoring and data memory „QuickData“.</p>

See the respective model designation on the pump type plate e.g. P233-2XL-1K6-24-2A5.10-MDF00

## Table of Contents

	Page		Page
<b>Fields of application of QUICKDATA</b>		<b>Low-level control</b> .....	<b>17</b>
<b>central lubrication pumps</b> .....	<b>2</b>	<b>Adjustment and operation of the control</b> .....	<b>18</b>
<b>Safety instructions</b> .....	<b>4</b>	Display mode .....	18
<b>Pump types</b> .....	<b>5</b>	Operating mode .....	19
<b>Identification code - pump models</b> .....	<b>6</b>	Programming mode .....	20
<b>Description of the QUICKDATA pump 233</b> .....	<b>8</b>	<b>Maintenance, repair and tests</b> .....	<b>21</b>
<b>Functions of the data logger</b> .....	<b>8</b>	Maintenance .....	21
<b>Mode of operation of pump 233</b> .....	<b>9</b>	Pump filling .....	21
Pump elements with fixed lubricant output .....	9	Repair .....	21
Suction phase .....	9	Tests .....	22
Delivery phase .....	9	Test run/To trigger an additional lubrication .....	22
Check valve .....	10	To check the pressure relief valve .....	22
Arrangement of the pump elements .....	10	<b>Troubleshooting</b> .....	<b>23</b>
Pump elements with adjustable lubricant output .....	10	<b>Technical data</b> .....	<b>24</b>
Adjustment of the output .....	11	Tightening torques .....	24
Retrofit adjustment of the max. output .....	11	Weights .....	24
Adjustment of small lubricant outputs .....	11	Diagram of electrical connections .....	25
Pressure relief valve .....	12	Dimensions .....	26
Return line connection .....	13	<b>Lubricants</b> .....	<b>32</b>
Printed circuit board with data logger .....	13		
Membrane key pad .....	15		

**Further information can be found in the following manuals:**

- Technical Description for „Diagnostic Software QuickData“ for pump 233 and QLS 333
- Technical Description for progressive divider valves models SSV and SSVM for grease and oil
- Installation instructions
- Parts Catalog
- Spare Parts Catalog for pumps 103 and 203

## Safety Instructions

### Appropriate Use

- Use the 233 pump only for dispensing lubricants in centralized lubrication systems. The pump is designed for interval operation.

### General Safety Instructions

- LINCOLN - QUICKDATA - centralized lubrication systems - are state of the art;
- can be assembled for safe operation
- Incorrect use may result in bearing damage caused by poor or excessive lubrication.
- Unauthorized modifications or changes to an installed system are not admissible. Any modification must be subject to prior consultation with the manufacturer of the lubrication system.

### Regulations for Prevention of Accidents

- Adhere to the regulations for prevention of accidents which are effective in the country where the system is to be used.

### Operation, Maintenance and Repair

- Repairs should only be performed by authorized and instructed personnel familiar with the regulations.
- LINCOLN - QUICKDATA - central lubrication pumps 233 must be operated only with fitted pressure relief valve.
- LINCOLN - QUICKDATA - central lubrication pumps 233 must be regularly refilled with clean lubricant.

**Attention: Before opening the reservoir cover for filling purposes, switch off the power supply.**

**Attention: When filling the reservoir by means of pumps with a large delivery volume do not exceed the max. filling mark. Risk of bursting if the reservoir is overfilled!**



- LINCOLN - QUICKDATA - central lubrication systems operate automatically. However, a regular check (about every two weeks) should be made to ensure that lubricant is actually reaching all the lubrication points.
- Defective printed circuit boards shall be suitably packed and returned to the factory.
- Dispose of used or contaminated lubricants in accordance with the legislation concerning the environment.

- The manufacturer of the centralized lubrication system will not accept any liability for:
  - damage caused by insufficient lubricant and irregular pump refilling,
  - damage caused by the use of used or contaminated lubricants,
  - damages due to the use of greases which are not or only conditionally pumpable in centralized lubrication systems,
  - damage caused by unauthorized modification of the system components,
  - damage caused by the use of unapproved spare parts.

### Installation

- Any safety equipment already fitted to the vehicle, device or machine:
  - should not be modified or made ineffective,
  - should only be removed for the purpose of fitting the system,
  - must be replaced afterwards.
- Keep QUICKDATA centralized lubrication systems away from sources of heat. Adhere to the operating temperature.
- Use only original LINCOLN spare parts (see Parts Catalog) or parts approved by LINCOLN.
- Adhere to:
  - the installation instructions of the manufacturer of construction machinery, vehicles or machines as regards all drilling and welding procedures,
  - the specified minimum distances between the bore holes and the upper/lower rim of the frame or between two bore holes.

## Pump Types



Fig. 1: - The different types of pump 233

- **The 233 pumps** differ from each other only in design and reservoir size.

- **Reservoir sizes:**

- 2 l transparent plastic reservoir
- 4 l transparent plastic reservoir
- 8 l transparent plastic reservoir

- **Electric connection**

The pumps model 233 may be equipped with a 10 m electric cable.

- All other data such as:

- motor voltage
- remote control for triggering an additional lubrication cycle
- design and number of pump elements
- design and number of pressure relief valves
- filling type
- use of return line connections
- low-level control (standard)

can be learnt from the pump type identification code\*.

- **Control unit models 233**

Integrated printed circuit boards with monitoring of the metering devices and the data logger „QuickData“ can be used with the 233 pumps.

\* Refer to the designation on the pump type plate, e.g. P233-2XLBO- 1 K6 - 24 - 2A5.10- MFD00, also refer to the identification code on page 6.

## Identification Code - Pump Models

Examples of model designations	P233-	2	X	L	-	1	K6	-	24-	2A	5.	10 - MDF 00	
	P233-	4	X	L	BO	-	1	K7	-	24-	2A	5.	10 - MDF 00
	P233-	2	X	L	BO	-	1	K6	-	12-	2A	5.	10 - MDF 00
	P233-	8	X	L	BO	-	1	K6	-	24-	2A	5.	10 - MDF 00

**Basic pump model for grease or oil**  
with 1-3 outlets and 12 V DC or 24 VDC motor

**Reservoir design**

2 - 2 l transparent plastic reservoir  
4 - 4 l transparent plastic reservoir  
8 - 8 l transparent plastic reservoir

X = reservoir for grease

L = low-level control

without designation=standard reservoir (2 l)  
BO = filling from top

**Pump elements**

1-3 = number of elements used

K 5 = piston diameter = 5mm  
K 6 = piston diameter = 6mm  
K 7 = piston diameter = 7mm  
KR = pump element, adjustable

**Motor voltage**

12V DC or 24V DC motor

**Number of electric connecting possibilities (on pump housing only)**

2A = 1 connection on the left side for power supply, external illuminated pushbutton for additional lubrication and fault indication,  
+ second connection (2 A - on the right side) for piston detector

**Type of connection**

5 = Euro plug\*

**Connection outside the pump**

00 = without socket, without cable  
10 = with socket and cable, 10 m length

**Control p.c.b. 12 V/24 V**

M DF 00 = with microprocessor control/ data logger/ membrane key pad

\* Other types of connection are possible on request.

Note: Any pump combinations other than the above standard pumps can be composed and ordered in accordance with the valid model identification code.

## Description of the QUICKDATA 233 Centralized Lubrication Pump

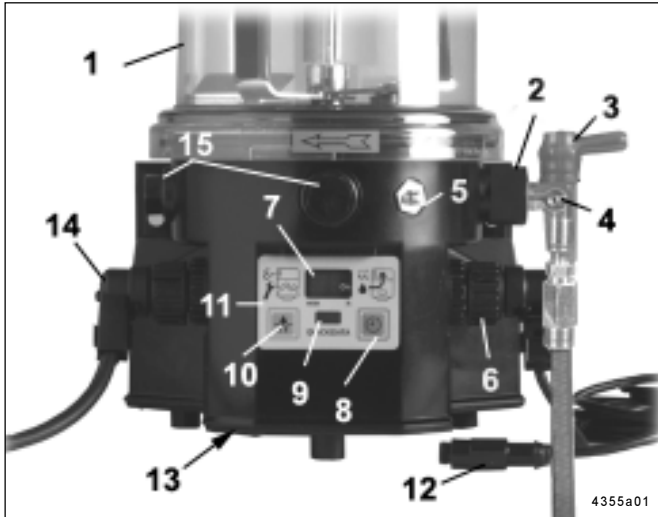

Fig. 2 - Components of pump 233

- |  |  |
|--|--|
| 1 - Reservoir  | 10 - Momentary-contact switch for additional lubrication         |
| 2 - Pump element   | 11 - Membrane key pad  |
| 3 - Pressure relief valve  | 12 - Piston detector   |
| 4 - Filling nipple, system<br>Emergency lubrication possible         | 13 - Control p.c.b. with data logger                             |
| 5 - Filling nipple, pump   | 14 - Adaptor for power supply<br>External illuminated pushbutton |
| 6 - Adaptor for piston detector                                      | 15 - Closure plug for the use of a pump element                  |
| 7 - Display  |  |
| 8 - Momentary-contact switch for indication or setting of pause time |  |
| 9 - Reading window for data logger                                   |  |

### Control and monitoring system „QuickData“

#### • The QUICKDATA 233 centralized lubrication pump

- is a compact multiline pump consisting of the following components:

- Housing with integrated motor
- Reservoir with stirring paddle and fixed paddle
- Data logger (control p.c.b. and readable data memory)
- Pump element
- Pressure relief valve
- Filling device
- Electrical connection parts

- can drive up to 3 pump elements with different outputs
- operates according to lubrication cycles (pause and operating times)
- is equipped with a low-level control
- can supply up to 300 lubrication points depending on the line lengths
- is designed for the automatic lubrication of the connected lubrication points
- is designed for the delivery of greases up to NLGI 2 at temperatures from -25°C to +70°C
- can be used with low-temperature greases down to temperatures of -40°C
- During the operating time the pump dispenses lubricant to the connected lube points via one divider valve model SSV...-N and several divider valves model SSV... .

#### • The control and monitoring system consists of:

- control p.c.b. MDF00 with
- built-on data logger module with IR interface
- membrane key pad with display
- IR interface module RS 232 (COM) for laptops without IR interface
- Software “QuickData“
- monitored divider valve model SSV...-N with integrated piston detector, see fig. 20.

### Control p.c.b. MDF 00 with data logger

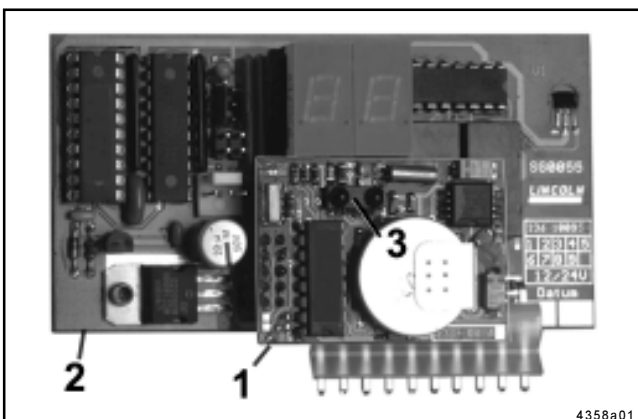

Fig. 3 - Control p.c.b. MDF 00 with built-on data logger

- The control is installed in the housing of the pump behind the membrane key pad as an integrated printed circuit board MDF 00 (2, fig. 3).
- The data logger (1) is fixed onto the printed circuit board.

- 1 - Data logger
- 2 - Control p.c.b.
- 3 - Infrared interface

Subject to change without notice

**Data Logger**

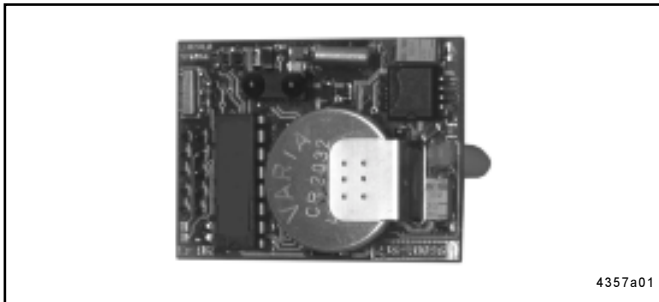

Fig. 3 - Data logger module

- Pump 233 is equipped with a readable data memory (data logger) „QuickData“.
- The data logger renders information regarding system settings, events such as low-level indications, malfunctions, operating times and lubrication cycles.
- By means of the Lincoln diagnostic software „QuickData“ the above mentioned data can be read on a suitable laptop via an infrared interface, see below Owner Manual „Diagnostic Software - QuickData“.

**Functions of the data logger**

**Printed circuit board MDF 00**

- The QUICKDATA centralized lubrication system is monitored, i.e.
- events such as malfunctions of the centralized lubrication systems, faults in the elapse of the operating time, low-level indications, pause times, residual pause times of the pump are displayed in the display window of the membrane key pad and transferred to the data logger.

**Data logger (data memory)**

- Malfunctions (start, end, duration) in the centralized lubrication system, faults in the elapse of the operating time, low-level indications (start, end, duration), number of connections and disconnections of the power supply, automatically triggered lube cycles, manually triggered lube cycles, operating data and customer-related data can be read and analyzed via laptop, see below diagnostic software „QuickData“.
- Functions, processes, settings, faults or malfunctions of the pump and the system are indicated on the membrane key pad as follows, also see below: Adjustment and Operation of the Control:

Pump 233:	Membrane key pad:	System:	Membrane key pad:
Failure in the power supply	No indication	Lubrication point or divider valve blocked	<b>Er</b>
Power supply ON	Right segment illuminated	Leakage in the main line from the pump to the monitored divider valve	<b>Er</b>
Failure in the membrane key pad	<b>EP</b>	Air entrapments in the grease	<b>Er</b>
Operating time elapses	Circulating segment	Failure in one lube cycle (depending on the installation of the monitored divider valve).	<b>Er</b>
Pump element does not dispense	<b>Er</b>		
Reservoir empty <i>Note: The fault indication „LL“ appears whenever the solenoid fixed to the stirring paddle has passed the proximity switch six times . Appearing „LL“ on the display, the lubrication cycle is being completed fully. Afterwards, the control does not switch the pump on automatically any longer.</i>	<b>LL</b>		
Pause time Residual pause time	<b>PP</b> <b>rP</b>		

Subject to change without notice



## Mode of Operation of Pump 233

### Pump elements with fixed lubricant output

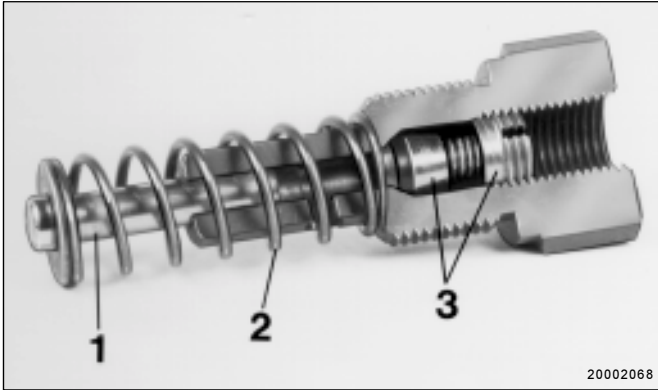

Fig. 6 - Pump element, sectional drawing  
1 - Piston  
2 - Return spring  
3 - Check valve

- The electric motor drives the eccentric (1, fig. 7, 8).
- During the operating time:
  - piston 2 sucks in lubricant from the reservoir, see fig. 7.
  - piston 2 dispenses the lubricant to the connected lubrication points via the metering devices, see fig. 8.
- The following designs are available:
 

Piston diameter, K5 .....	5 mm
Lubricant output .....	approx. 2 cm <sup>3</sup> /min
Piston diameter, K6 (Standard) .....	6 mm
Lubricant output .....	approx. 2.8 cm <sup>3</sup> /min
Piston diameter, K7 .....	7 mm
Lubricant output .....	approx. 4 cm <sup>3</sup> /min
- Tightening torque.....25 Nm

### Suction Phase

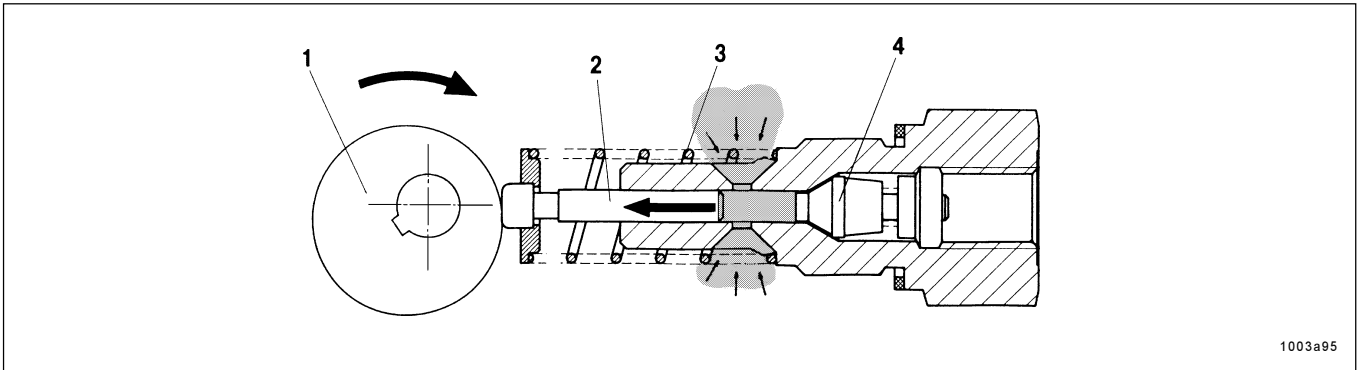

Fig. 7 - The pump element sucks in lubricant.

- |               |                 |
|---------------|-----------------|
| 1 - Eccentric | 3 - Spring      |
| 2 - Piston    | 4 - Check valve |

### Förderphase

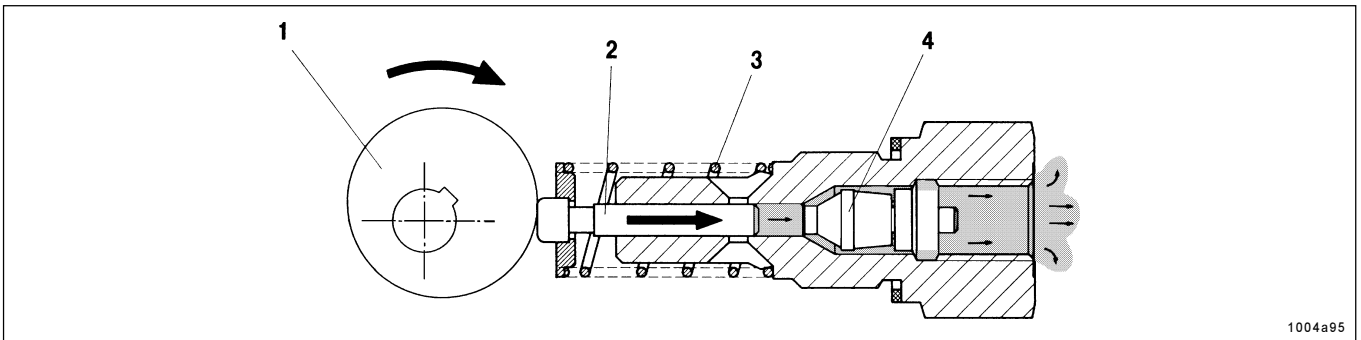

Fig. 8 - The pump element dispenses lubricant

- |               |                 |
|---------------|-----------------|
| 1 - Eccentric | 3 - Spring      |
| 2 - Piston    | 4 - Check valve |

Subject to change without notice

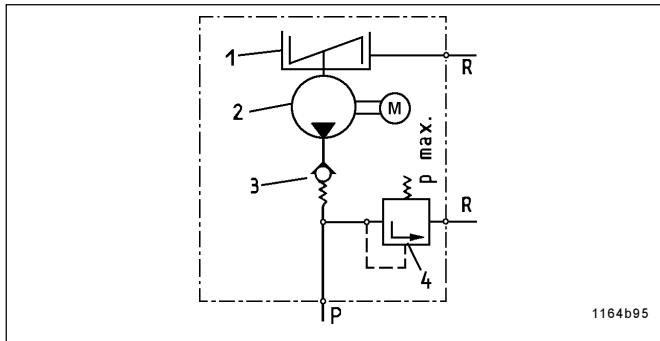

Fig. 9 - Hydraulic diagram of the pump

**Check valve**

- The check valve:
  - serves for the function of the pump element
  - prevents the lubricant from flowing back to the housing or reservoir

- 1-Reservoir with stirring paddle
- 2-Pump
- 3-Check valve, spring-loaded
- 4-Pressure relief valve
- R-Return line
- p-Pressure line

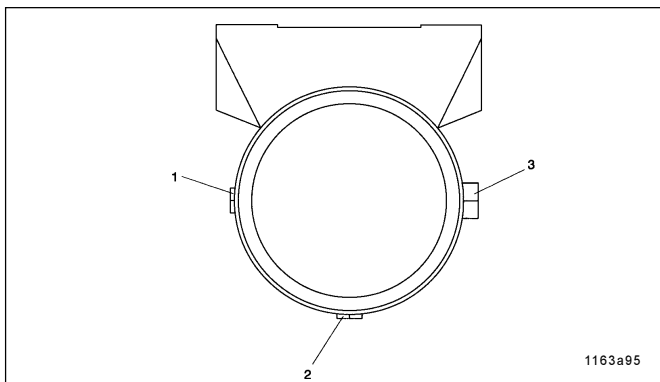

Fig. 10 - Arrangement of the pump elements

**Arrangement of the pump elements**

- If several pump elements are to be installed, the installation arrangement shown in fig. 10 must be adhered to.
- If there is **only one** pump element, it can be installed in **any position**.
- If there are two pump elements, install one in position 3 and the other in position 1.

**Pump element with adjustable lubricant output**



Fig. 11 - Adjustable pump element

- The mode of operation (suction and supply phase) is the same as that of the pump elements with fix lubricant output.
- The lubricant outputs are adjustable from 0.04 to 0.18cm<sup>3</sup>/ stroke or from 0.7 to 3cm<sup>3</sup>/ min.
- The pump elements are factory-set to the maximum lubricant output whereby the adjusting size „S“ should be 29 ± 0.1mm (fig. 12).

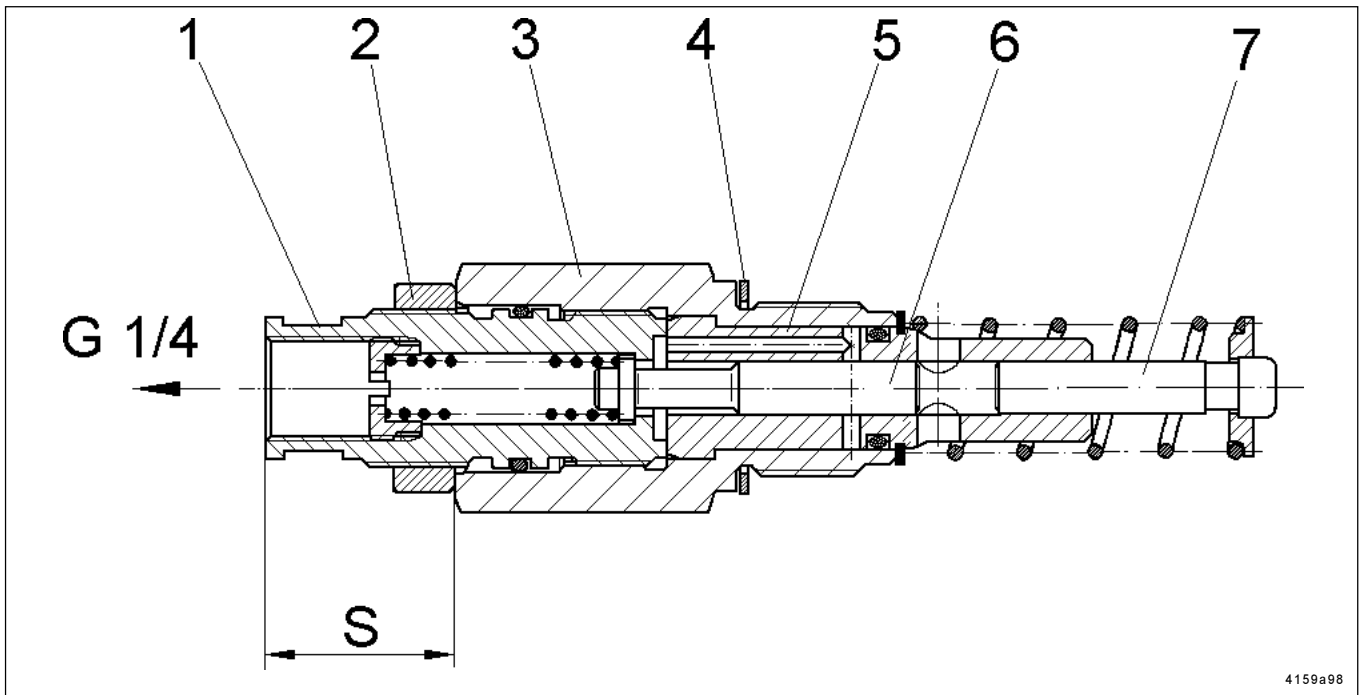

Fig. 12 - Sectional view: Adjustable pump element

- 1 - Adjusting spindle SW 16 (with over flats)
- 2 - Counter nut SW 24

- 3 - Pump element body
- 4 - Gasket
- 5 - Pump cylinder

- 6 - Control piston
- 7 - Delivery piston
- S - Size

### Setting of the output

- \* Unscrew the coupling nut for fixing the pressure relief valve.
- \* Loosen counter nut (2, fig. 12) while holding in position pump element body (3) by means of a second wrench.

- \* Adjust the regulating spindle (1) by means of a wrench, see output diagram (fig. 13)
- \* The size „S“ (see fig. 12) for the desired lubricant output can be ascertained by using the delivery diagram shown in fig. 13.

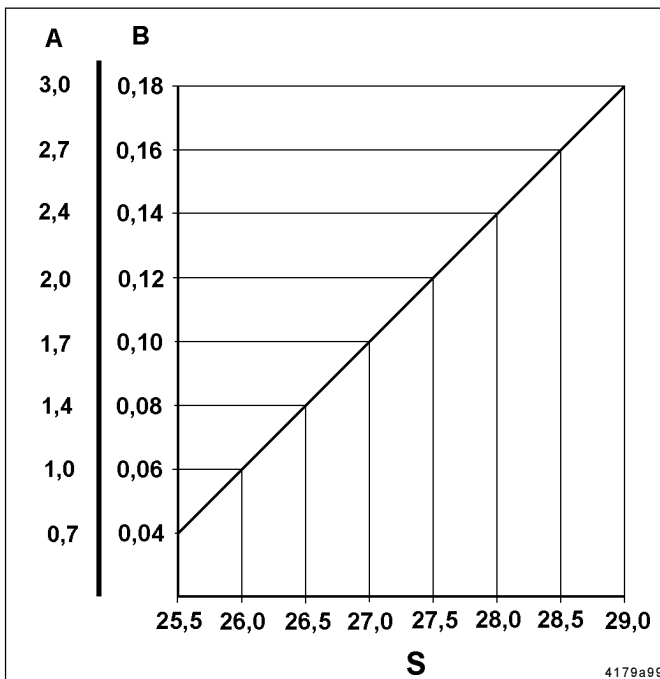

Fig. 13 - Delivery diagram

- A - Lubricant output in cm<sup>3</sup>/minS - Size
- B - Lubricant output in cm<sup>3</sup>/stroke

### Retrofit adjustment of maximum lubricant output:

*Note: In order to ensure that the lubricant output setting will be as exact as possible, first the actual size „S“ of the max. lubricant output must be ascertained as follows. The measured difference to the nominal value 29 mm must be considered for all other setting values (e.g. ± 0,1).*

- \* Unscrew the adjusting spindle (1, fig.12) out of the pump element body (3) until „S“ is approx. 30 mm.
- \* Screw counter nut (2) onto stop collar of the adjusting spindle (1).
- \* Screw adjusting spindle (1) with counter nut (2) into pump body (3) until stop.

### Adjustment of small lubricant output:

- \* Before the pump element can be adjusted to a small lubricant output, the size „S“ for max. lubricant output must be ascertained, and the difference to the nominal value 29 mm must be transferred to any desired setting between 25.5...28.5 mm.
- \* Dimension „S“ must be adjusted to the desired value in accordance with the delivery diagram (fig. 13).

*Note: At maximum setting, „S“ is 29±0.1 mm.*

Subject to change without notice

## Pressure Relief Valve

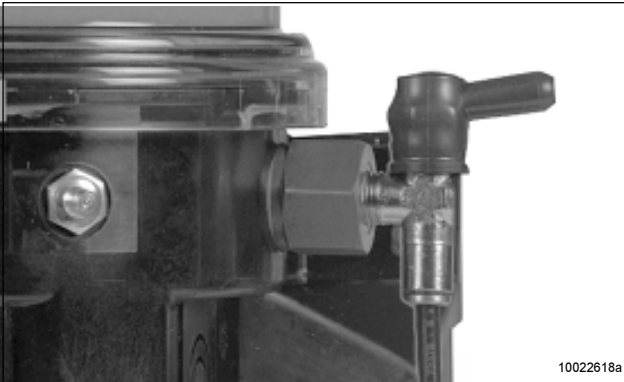

Fig. 14 - Pressure relief valve

### Pressure relief valve without grease return

**Important!** Each pump element must be secured with a pressure relief valve.

- The pressure relief valve
  - limits the pressure build-up in the system
  - opens when the respective overpressure is reached.
  - must be selected according to the requirements of the lubrication system (see different opening pressures: 200, 270, 350 bar).
- If lubricant is leaking at the pressure relief valve, this indicates a malfunction in the centralized lubrication system or the lubrication point.

*Note: There may arise a longer time delay between a malfunction (blockage) and the consequential fault indication (lubricant leakage; monitor: flashing display of „Er“ on the membrane key pad).*

*The duration of the delay depends on the type of line, the line lengths, the type of lubricant, the ambient temperature and other influences.*

- Despite the existing failure monitor, carry out a visual control as well as a function control in regular intervals.

### Pressure relief valve with grease return (optional)

- If the system is blocked, grease will leak from the pressure relief valve. This grease quantity is returned to the reservoir.



Fig. 15 - Pressure relief valve with grease return

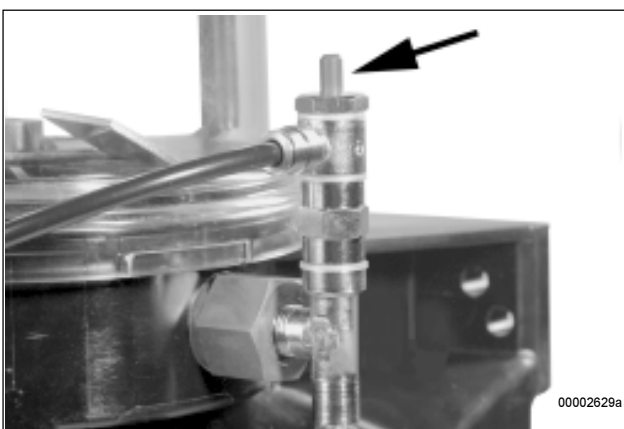

Fig. 16 - Fault indication in the case of a blockage

- In the case of a blockage in the system, the grease pushes out the red pin at the pressure relief valve thus indicating that there is a fault.

### Return Line Connection



Fig. 17 - Return line connection

- Lubricant quantities which cannot be dispensed by the metering device must be returned to the pump via the return line connection (fig. 15).

### Printed circuit board with data memory

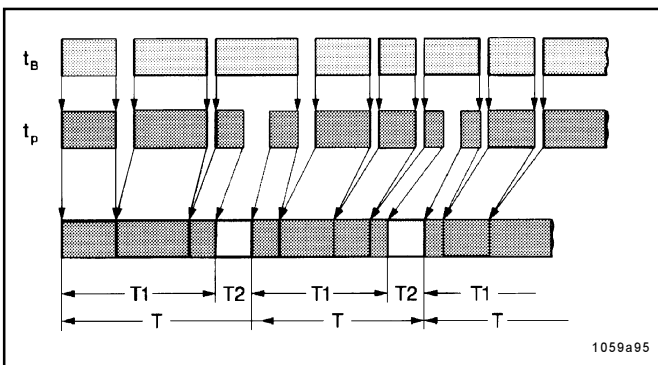

Fig. 18 - Time sequence diagram

$t_B$  - Working hours  
 $t_P$  - Individual pause times  
T - Lubrication cycle  
T1 - Stored pause times  
T2 - Operating times

- The printed circuit board automatically controls the sequence of the pause and operating times of the 233 centralized lubrication pump as a function of the vehicle or machine working hours  $t_B$  (fig. 18).
- The sequence of the pause and operating times is activated when the machine contact or driving switch is switched on, i.e. the centralized lubrication pump is ready for operation.
- A lubrication cycle consists of one pause time and one operating time. Once the pause time has elapsed, the operating time starts to run. This lubrication cycle is repeated permanently after the machine or vehicle has been put into operation (fig. 18).
- During the operating time the pump element dispenses the lubricant to the lubrication points via progressive divider valves.

#### Pause time

- The pause time
  - determines the frequency of the lubrication cycles within a working cycle;
  - is started and stopped via the machine contact or driving switch
  - is adjustable
- When the machine contact or the driving switch is switched off, the pause times which have already elapsed are stored and added up by an **electronic data memory** (EEPROM) until the time which has been set on the membrane key pad is reached.
- After the machine contact or driving switch is switched on again, the printed circuit board operates from the point where it had been interrupted.
- If the setting is modified within the pause time, the printed circuit board takes over the new value automatically on completion of the programming procedure (see Programming Mode).
- The pause time setting may be different for each application. It must be adjusted in accordance with the respective lubrication cycles (see Programming Mode).
- Standard setting: 6 hours.

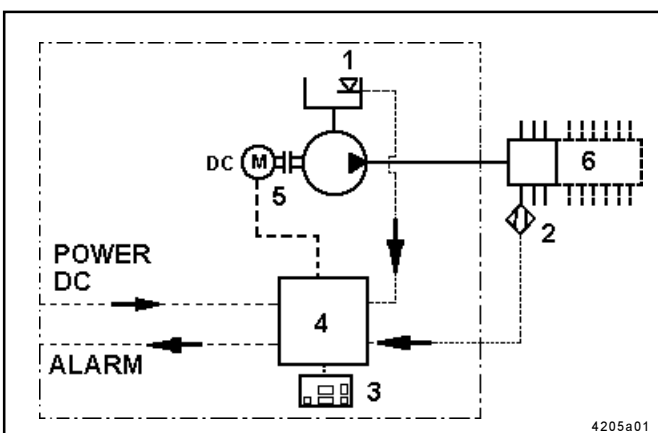

Fig. 19 - Pump 233 with data logger, schematic drawing

1 - Low-level control  
2 - Piston detector  
3 - Membrane key pad  
4 - Control p.c.b. with data logger  
5 - Pump  
6 - Lubricant divider valve SSV N

Subject to change without notice

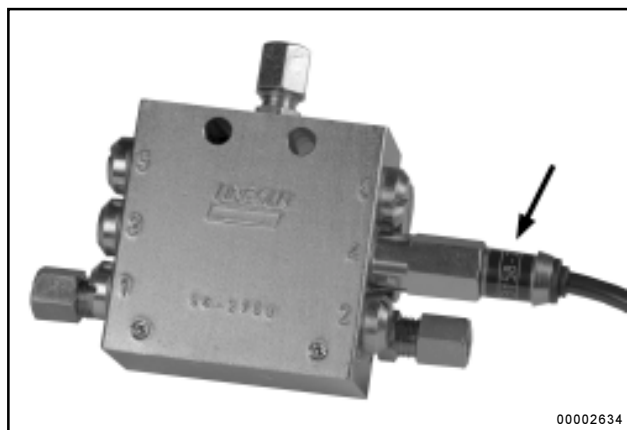

Fig. 20 - Piston detector

#### Operating time

- A **piston detector** (initiator) which has been installed on a metering device instead of a piston closure plug, monitors and brings the pump **operating time** to a close after all the pistons of this metering device have dispensed their lubricant quantity once.
- The operating time depends on the system's lubricant requirement and on the location of the piston detector (either on the main metering device or on the secondary metering device).
- During the pump operating time a circulating segment appears in the display of the membrane key pad (see Display of the membrane key pad).
- After an interruption of the operating time, e.g. by switching off the power supply, the operating time continues from the point where it had been interrupted.
- When the machine contact or the driving switch is switched off, the pause times which have already elapsed are stored and added up by an **electronic data memory** (EEPROM) until the piston detector stops the operating time.

#### Monitoring time

*Note: Only one lubrication cycle can be monitored.*

- A fixed **monitoring time** of a maximum of 30 minutes runs in parallel to the operating time.

*Note: Normally, the monitoring time ends at the same time as the operating time.*

- If there is **no switching off signal** from the piston detector (fig. 20) to the printed circuit board within 30 minutes a **fault signal** will occur (see Display of the membrane key pad).
- An external **signal lamp** flashes **continuously** in case of a fault.

#### External triggering of additional lubrication

- \* Press pushbutton for more than 2 seconds.



Fig. 21 - External triggering of an additional lubrication

### Membrane key pad

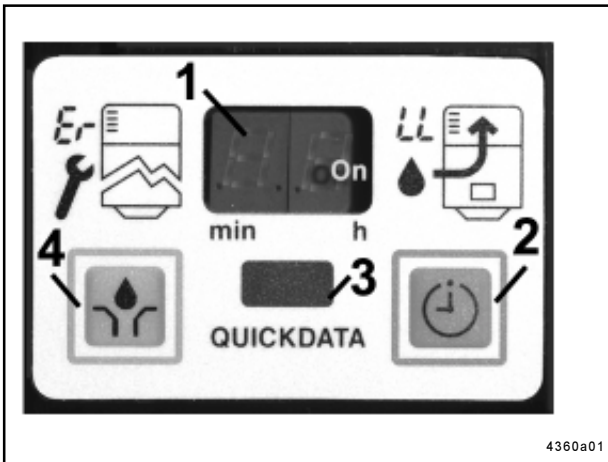

Fig. 22 - Membrane key pad with display and reading window

- The membrane key pad serves for:
  - displaying functions, faults, low-level indications and time settings in the display window 1, fig. 22 (display mode)
  - setting the pause time (programming mode)
  - triggering one or several additional lubrications (operating mode)
  - reading of data and events

- 1 - Display window
- 2 - Key for acknowledgment of fault indications and setting of time (shift key)
- 3 - Reading window for „QuickData“ data
- 4 - Key for triggering an additional lubrication and for setting the time values

### Display window of the membrane key pad

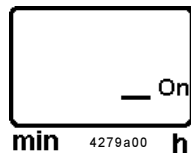

Fig. 23 - Green segment, pause time, voltage applied

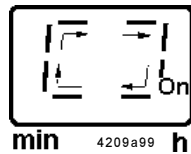

Fig. 24 - Green circulating illuminated segment, operating time



Fig. 25 - Key for triggering an additional lubrication

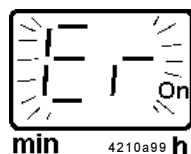

Fig. 26 - Display of a fault signal

- As soon as voltage is applied (On), the lower right-hand segment in the display window flashes (pause time runs).
- If the power supply is interrupted during the pause time, after switching it on again, the pause time continues at the point of interruption.
- During the operating time of the pump, a circulating illuminated segment appears in the display window of the membrane key pad.
- If the power supply is interrupted during the operating time, after switching it on again, the operating time continues at the point of interruption.

#### • Additional lubrication

- is triggered via the key of fig. 25. Press key for more than 2 seconds.
- can be triggered at any time provided that voltage is applied.

*Note: If a malfunction is present (flashing display), first acknowledge the malfunction, then trigger an additional lubrication (see fig. 28).*

- If a fault signal (malfunction) is present, it will be cancelled whenever the system is operating properly.

#### Monitoring time/ malfunction

- If there is no feedback from the piston detector (initiator) within **30 minutes** (monitoring time) from completion of the pause time or from triggering an additional lubrication, the pump switches off immediately. The fault signal \* Er \* (error) is displayed as a flashing light in the display of the membrane key pad.

- If a malfunction is present, the pump does not switch on automatically any longer.

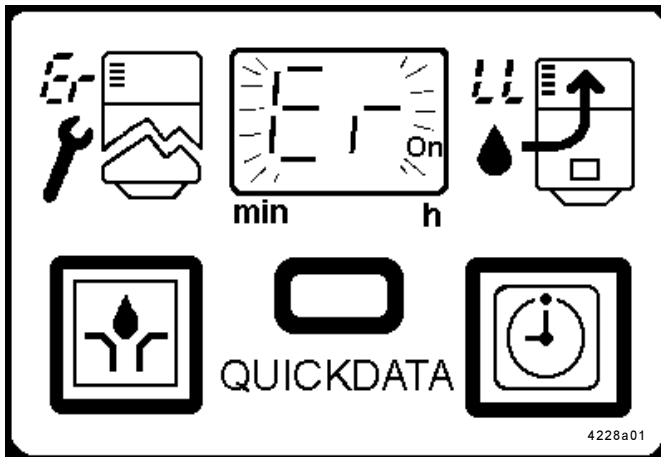

Fig. 27 - Membrane key pad with fault signal

- In this case, switch on the pump by pressing the key for additional lubrication (fig. 25). Acknowledge the malfunction before doing so.
- When a malfunction is present, it can only be cancelled by triggering an additional lubrication and after a proper lubrication cycle has been executed.
- If the fault is still present after an additional lube cycle has been triggered, the fault signal \* ER \* is again displayed in the display of the membrane key pad.
- The monitoring time starts at the same time as the operating time. It is a fixed time of 30 minutes.
- If the voltage supply is interrupted during the monitoring phase (operating time), the monitoring time starts from the beginning after the pump has been switched on again.

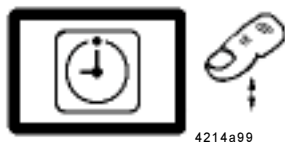

Fig. 28 - Acknowledging a flashing fault signal „Er“

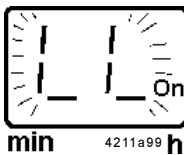

Fig. 29 - Display of a low-level indication

#### Acknowledging the malfunction

- On pressing the key (fig. 28), the flashing display \* Er \* changes into a continuous light.
- An external signal lamp switches off.

#### Low-level indication

- When the reservoir is empty the display on the membrane key pad shows the flashing fault signal \*LL\*.
- The function of the low-level control is described on page 17.
- In the case of a low-level indication the pump does not switch off immediately. The current lube cycle is completed. Upon expiration of the pause time, the pump cannot be started automatically again. The flashing indication \* LL\* appears on the display of the membrane key pad (fig. 29).

\* Before filling the reservoir, press the key, fig. 30, to acknowledge the low-level indication.

\* Fill pump and trigger additional lubrication. As soon as the additional lube cycle has been triggered, the „ LL “ display is cancelled. The automatic lube cycle resumes.

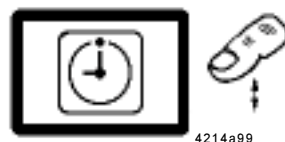

Fig. 30 - Acknowledging a flashing fault signal „LL“

#### Acknowledging the low-level indication

- By pressing the key (fig. 30) the flashing light \* LL \* is changed into a continuous light (fig. 31).
- An external signal lamp switches off.

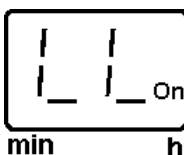

Fig. 31 - Acknowledged fault signal „LL“

#### Malfunction/ low-level indication

- If both indications occur at the same time, then both displays \* Er \* and \* LL\* will flash alternately.

#### Monitoring relay (on the control p.c.b.)

- The monitoring relay signalizes a low-level indication or a malfunction. In both cases, the monitoring relay will pick up. Via a minus potential contact, a signal lamp can be used as external fault indication which has to be switched against plus. Whenever the fault indication is acknowledged, the flashing indication switches to a continuous indication.

*Note: If the fault has not been put in order properly, after switching the pump off and on, an acknowledged fault/ low-level indication will appear as a flashing indication in the display window again.*





Fig.32 - Reading of the data memory

#### Reading of the data memory „QuickData“

\* Read data memory via a suitable laptop with integrated or, if not available, external infrared interface (see Owner Manual „Diagnostic Software - QuickData“). To be able to read from the reading window, place the infrared interface of the laptop at a maximum distance of 1m horizontally in front of it, then read the data.

#### Hardware requirements

Operating system: MS Windows 98 or 98/2000  
Computer: IBM AT or compatible device, 486 DX or faster, 16 MB RAM hard disk with a minimum of 1 MB free memory  
a free serial connection (COM-Port, 9-pole)  
mouse (bus-type)  
3 1/2" HD disk drive

#### External infrared interface

Part n°. 236-10127-1  
Protocol: IrDA 1.219200/8/N Baud  
Plug-in for COM-Port (RS 232, 9-pole  
SubD - plug; socket)  
Reach approx. 1 m

## Low-Level Control

### Low-level control for grease

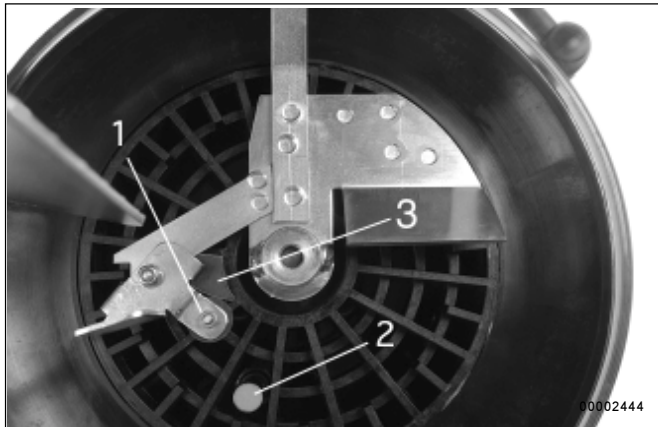

Fig. 33 - Switching parts of the low-level control

- 1 - Guiding plate with round solenoid
- 2 - Electromagnetic switch (at stirring paddle)
- 3 - Control cam

*Note: The switching parts listed above are not suitable for liquid grease. In such a case a float magnetic switch must be used (see Low-level control for oil).*

#### Full reservoir

- The stirring paddle rotates **clockwise** during the operating time.
- Due to the rotating motion of the stirring paddle in the lubricant the pivoting guiding plate with the round solenoid, item 1 fig. 33, is pressed backwards. The solenoid moves towards the center of rotation of the stirring paddle. The electromagnetic switch, item 2, **cannot** be activated.
- Control cam, item 3, guides the round solenoid with the pivoting guiding plate automatically outwards, in the direction of the reservoir wall. After the lubricant has left the control cam, it flows against the guiding plate, thus displacing the solenoid again onto the center of rotation of the stirring paddle.

#### Reservoir empty

- During the rotating motion of the stirring paddle there is no backpressure from the lubricant. The guiding plate with the round solenoid no longer moves towards the center of rotation of the stirring paddle. After control cam, item 3, has been overtravelled, the solenoid remains in the outer position and overruns the electromagnetic switch 2. The solenoid activates the electromagnetic switch contact-free thus triggering a low-level signal. The operating time is stopped by the piston detector.

*Note: The flashing signal „LL“ appears only after the solenoid has activated the electromagnetic switch 6 times contact-free.*

#### Magnetic switch

- The electromagnetic switch is activated contact-free and without wear by the magnetic field of the solenoid fitted to the stirring paddle.

## Setting and Operation of the Control

- Three possible modes of operation and settings can be selected on the membrane key pad.
  - Display mode
  - Operating mode
  - Programming mode

### Display mode

	<ul style="list-style-type: none"> <li>• As soon as voltage is applied to pump P 233, the control is automatically in the <b>display mode</b>. The <b>right segment</b> on the display is illuminated (On).</li> <li>• Normally, the display is dark. Only the functions (segment, circulating segment display) or malfunctions (* Er *, or * LL *) appear illuminated in the display.</li> </ul>
	<ul style="list-style-type: none"> <li>• <b>Display mode</b></li> <li>- Here the user receives information on functions and malfunctions of pump P 233.</li> <li>- A test display is made when the voltage is applied, all segments are illuminated for 2 seconds. <i>Note: If * EP * is displayed after the display test, this indicates that keys of the membrane key pad are defective.</i></li> </ul>
	<ul style="list-style-type: none"> <li>- The right-hand segment (On/h) indicates the available voltage supply during the pause time. As soon as another message is displayed, the segment turns off.</li> </ul>
	<ul style="list-style-type: none"> <li>- The operating time is displayed as a circulating segment.</li> </ul>
	<ul style="list-style-type: none"> <li>- * Er * is displayed as a flashing indication for a malfunction.</li> <li>- * LL* is displayed as a flashing indication for a low level.</li> </ul>
	<ul style="list-style-type: none"> <li>- The flashing display is changed into a continuous light by pressing this key (<b>acknowledging</b>). To <b>acknowledge</b>, press the key only briefly (less than 2 seconds).</li> </ul>
	<ul style="list-style-type: none"> <li>• Signals which have been acknowledged but have not yet been remedied, flash again after the pump has been switched off and on again.</li> </ul>

Fig. 34 - Membrane key pad in display mode

Subject to change without notice

Operating mode





Display	Press	
 min 4279a00 h  min 4209a99 h	 4222a99  ≥ 2 sec	<p><b>Important:</b> The operating mode is accesible only during the pause time and cannot be operated during the running time (pump operating time).</p> <ul style="list-style-type: none"> <li>• Precondition: When the voltage supply is applied, the segment (On/h) is lit.</li> </ul> <p><b>Operating option: Trigger an additional lube cycle</b></p> <p>* Press this key. The pause time already elapsed is reset. The operating time starts. A circulating segment is visible on the display during the whole operating time.</p>
 min 4279a00 h  min 4123a99 h  min 4216a99 h  min 4220a99 h  min 4224a99 h  min 4225a99 h  min 4226a99 h  min 4279a00 h	 4214a99  ≥ 2 sec  after 2 sec.  after 2 sec.  after 2 sec.  after 2 sec.  after 2 sec.  after 60 sec.	<p><b>Operating option: Read information on how to set the pause time and remaining pause time.</b></p> <p>* Press this key.</p> <p><i>Note: The following display sequence is shown <b>twice</b> and is cancelled after 60 seconds. The change of display occurs every two seconds. Example:</i></p> <p><b>PP = 12h 30min</b>  <b>rP = 5 h 10 min</b>                  „ PP “ (set pause time)                  12 . (hours)</p> <p>. 30 (minutes)</p> <p>„ rP “ (remaining pause time)</p> <p>5 . (hours)</p> <p>. 10 (minutes)</p> <p>occurs after second sequence</p>

Fig. 35 - Membrane key pad in operating mode

Subject to change without notice

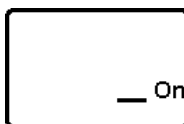
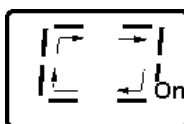
**Programming mode**

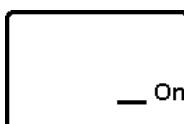
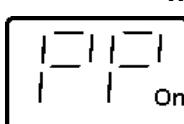
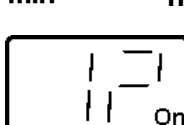
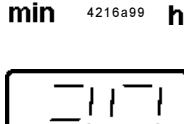
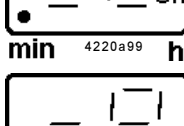
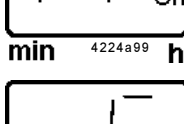
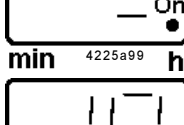
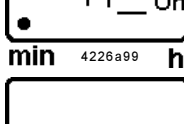
<p><b>Display</b> <b>Press</b> <b>Press</b></p>	<p>* To access the programming mode, <b>press both keys at the same time &gt; 4 seconds</b>.</p> <p><b>Programming options - Pause time:</b></p> <table border="0"> <tr> <td>P1</td> <td>0 - 59 hours</td> </tr> <tr> <td>P2</td> <td>0 - 59 minutes</td> </tr> <tr> <td>Min. pause time</td> <td>4 minutes</td> </tr> <tr> <td>Max. pause time</td> <td>59 hours 59 minutes</td> </tr> </table>	P1	0 - 59 hours	P2	0 - 59 minutes	Min. pause time	4 minutes	Max. pause time	59 hours 59 minutes
P1	0 - 59 hours								
P2	0 - 59 minutes								
Min. pause time	4 minutes								
Max. pause time	59 hours 59 minutes								
	<p><b>Set hours P1</b>  (set key)</p> <p>* Settings are made in one direction: 0, 1, 2, 3, ... 59 h          Key pressed once.....increases by 1 hour          Key pressed continuously.....quick sequence</p> <p>• The fields „hour“ and „minutes“ are indicated by a <b>decimal point on the right hand for hours and on the left hand for minutes</b>.</p>								
	<p><b>Set minutes P2</b>  (shift key)</p> <p>* Settings are made in one direction: 0, 1, 2, 3, ...59 min          Key pressed once.....increases by 1 minute          Key pressed continuously.....quick sequence</p> <p><i>Note: The minimum pause time begins with 4 minutes. When pause times &lt; 4 minutes (no indication of hour) the display automatically indicates . 04. Precondition: The programming sequence must have been carried out completely.</i></p>								
	<p><b>Complete programming mode</b></p> <p>* Press key. „ P -“ indicates the programming end.  <b>Important:</b> In order to avoid a wrong programming, make sure to always carry out the programming sequence completely, i.e. setting of P1 (hours), P2 (minutes) and P-(programming end).</p> <p>• Complete the programming by pressing this key (additional lubrication).</p> <p><i>Note: If the displayed key „additional lubrication“ is not pressed within 30 seconds, the programming mode remains in the previously set time.</i></p> <p><b>Important:</b> After completion of the programming sequence, also check the setting of the pause time in the operating mode (see page 13).</p>								

Fig. 36 - Membrane key pad in programming mode

## Maintenance, Repair and Tests

### Maintenance

- The maintenance is essentially limited to refilling the reservoir with clean lubricant in good time. However, check regularly whether the lubricant is really dispensed to all the lubrication points.
- Also check the main lines and lubricant feed lines for damage and replace them, if necessary.

*Note: Whenever work is done on the centralized lubrication system, particular attention should be paid to absolute cleanliness. Dirt in the system will cause problems.*

- For cleaning the system use benzine or petroleum. Do not use tri-, perchloroethylene or similar solvents. Also do not use polar organic solvents such as alcohol, methylacohol, acetone or similar

### Pump filling



Fig. 37 - Fill pump reservoir

### 2 l, 4 l, 8 l - reservoirs

Fill the reservoir up to the „Max.“ mark via the filling nipple or a coupling or and adaptor.

It is possible to use greases up to penetration class NLGI 2.

**Important!** The grease must be free from impurities and must not be liable to change its consistency in the course of time.

**Attention:** If the pump is filled via the upper filling opening, switch off the power supply before starting filling.



**Attention:** When filling the reservoir by means of pumps with a large delivery volume do not exceed the max. filling mark. Risk of bursting if the reservoir is overfilled.

*Note: If the reservoir has been completely emptied, the pump may require up to 10 minutes before it operates with its full output.*

### Repair

#### Pump

- Use only original LINCOLN spare parts for repair on the pumps.
- Return the pump to the factory for warranty work or major repairs.
- Pack defective printed circuit boards suitably and return to the factory.

### Replace the pump element

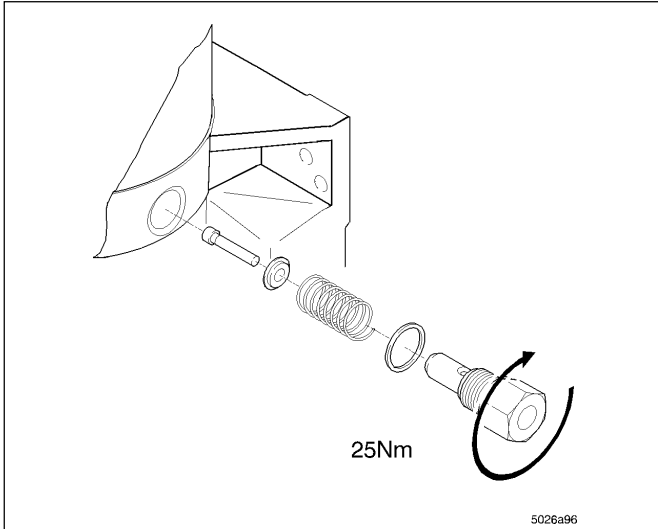

Fig. 38 - Replacing the pump element

- \* Remove the pressure relief valve from the pump element.
- \* Unscrew the pump element. Take care that the piston, the pull-back spring and the washer are not left lying in the grease, otherwise the reservoir must be disassembled in order to remove these pieces.

**Important:** Do not leave the piston, spring and washer in the housing because they may block the motor.

- \* Install a new pump element and a new sealing ring. Make sure that only **one** sealing ring is installed below the pump element.

*Note: Pump element with adjustable lubricant output must be set to the corresponding output.*

### Tests

#### Operational Test/ Triggering an Additional Lube Cycle

- To check the pump operation it is possible to perform an additional test. Refer to „Trigger additional lubrication“ below „Display window of the membrane key pad“.

## Troubleshooting

### Pump 233

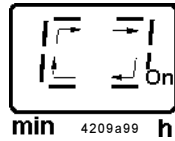

- The circulating segment in the display of the membrane key pad indicates that the pump operates properly.

<ul style="list-style-type: none"> <li><b>Fault: Pump motor does not run; stirring paddle does not turn</b></li> </ul>	
<ul style="list-style-type: none"> <li><b>Cause:</b></li> <li>Power supply interrupted. Segment display for On/h is not lit.</li> <li>Power supply from printed circuit board to motor interrupted. Electric motor defective.</li> <li>Printed circuit board defective.</li> <li>Key on membrane key pad defective.</li> </ul>	<ul style="list-style-type: none"> <li><b>Remedy:</b></li> <li> Check the voltage supply to the pump/fuses. If necessary, eliminate the fault or replace the fuses.</li> <li>Check the feed line from the fuses to the plug of the pump and then to the printed circuit board.</li> <li>Trigger an additional lube cycle. Check voltage supply from the p.c.b. to the motor, if necessary replace motor.</li> <li>Replace p.c.b.</li> <li>*EP* display is lit. Replace housing and membrane key pad.</li> </ul>
<ul style="list-style-type: none"> <li><b>Fault: Pump does not deliver lubricant</b></li> </ul>	
<ul style="list-style-type: none"> <li><b>Cause:</b></li> <li>Reservoir empty. * LL * display on the membrane key pad is flashing.</li> <li>Pump does not deliver lubricant and *Er * display on the membrane key pad is flashing.</li> <li>Air pockets in the lubricant.</li> <li>Improper lubricant has been used.</li> <li>Suction hole of pump element clogged.</li> <li>Pump piston is worn.</li> <li>Check valve in pump element defective or clogged.</li> </ul>	<ul style="list-style-type: none"> <li><b>Remedy:</b></li> <li>Fill up the reservoir with clean grease. Let the pump run (trigger additional lube cycle) until the lubricant shows at all lube points. <i>NOTE: Dependent on the ambient temperature and/ or type of lubricant. the pump element needs a longer run time to reach the full output capacity. Therefore, trigger several additional lube cycles.</i></li> <li>Trigger several additional lube cycles. Lubricant must be dispensed without air bubbles (towards the lube point).</li> <li>Change lubricant. Consider table of lubricants.</li> <li>Remove pump element. Check suction hole for foreign particles. If there are any, remove them.</li> <li>Replace pump element.</li> <li>Replace pump element.</li> </ul>
<ul style="list-style-type: none"> <li><b>Pump motor does not stop dispensing (30 minutes monitoring time)</b></li> </ul>	
<ul style="list-style-type: none"> <li><b>Cause:</b></li> <li>Piston detector (initiator) defective.</li> <li>Blockage in the system</li> <li>Cable connections from the piston detector towards the pump interrupted.</li> <li>Printed circuit board defective.</li> </ul>	<ul style="list-style-type: none"> <li><b>Remedy:</b></li> <li>Remove main line towards the monitored divider valve.</li> <li>Unscrew and check piston detector by introducing a <b>iron pin</b> into the borehole of the detector, <b>maintain it there for more than 2 seconds and pull out again</b>. If then the pump switches off, a blockage may exist; if the pump does not switch off, check cable connections towards the pump. If necessary, replace piston detector with connecting plug.</li> <li>Check cable connections towards pump. If necessary, replace piston detector with connecting plug.</li> <li>Exchange printed circuit board.</li> </ul>

Subject to change without notice

## Technical Data

### Pump

Admissible operating temperature ..... -40° C to 70° C\*  
 Number of outlets ..... 1, 2 or 3  
 Reservoir capacity ..... 2 l, 4 l, 8 l  
 Filling ..... via hydr. lubrication fitting from top  
 Lubricant ..... Greases up to NLGI 2

Protection ..... IP6K 9K acc. DIN 40050 T9  
 Reverse polarity protection:  
 The operating voltage inlets are protected against reverse polarity.

*\*NOTE: The pump is suitable for the above mentioned temperature range. Lubricants, however, can normally be dispensed up to -25°C only. For lower temperatures, low-temperature greases have to be applied.*

### Electric values DC (direct current)

Operating voltage ..... 12 V, - 20%/+ 30 %  
 Max. operating current ..... 2,0 A  
 Operating voltage ..... 24 V, - 20%/+ 30 %  
 Max. operating current ..... 1,0 A  
 Residual ripple in relation to the  
 operating voltage ..... ± 5% acc. to DIN 41755

*Note: The pump motors are suitable for interval operation only.*

- Additionally to the EMV regulation, the **DC systems** comply with the following directives and standards:
  - Vehicle guideline 95/245/EC
  - EN 40839 parts 1, 3 and 4

### Time setting

Factory setting .....  
 Pause time ..... 6 hours/cycle  
 Pause time range ..... 4 minutes up to 60 hours,  
 ..... , increment 1 minute

### Relay for malfunction

malfunction/ low-level control  
 Switching voltage ..... max. 48 VAC/ VDC  
 Switching current ..... max. (resistive) 2 A  
 Switching capacity ..... max. 100 VA/80 W

*Note: All data depends on operating voltage, ambient temperature and max. operating pressure.*

### Pump element with fix output

Piston diameter, K5 ..... 5 mm  
 Output ..... approx. 2 cm<sup>3</sup>/min  
 Piston diameter, (standard) K6 ..... 6 mm  
 output ..... approx. 2,8cm<sup>3</sup>/min  
 Piston diameter, K7, ..... 7 mm  
 output ..... approx. 4cm<sup>3</sup>/min  
 Max. admissible operating pressure ..... 350 bar  
 Connecting thread ..... G 1/4  
 suitable for tube diameter ..... 6 mm  
 suitable for tube diameter ..... 8 mm

### Pump element with adjustable output

KR ..... 0.04 up to 0.18 cm<sup>3</sup>/Hub  
 ..... 0.7 bis 3 cm<sup>3</sup>/min  
 Connecting thread ..... G 1/4"  
 suitable for tube diameter ..... 6 mm  
 suitable for tube diameter ..... 8 mm

**IMPORTANT:** The outputs indicated refer to greases of NLGI grade 2, measured at 20°C, 100 bar backpressure and 12V/ 24V operating voltage. Any differing pressures or temperatures result in different lubricant outputs. Any system design must be based on the above values.

### Tightening torques

Install pump ..... 18 Nm  
 Electric motor on housing ..... 12 Nm  
 Pump element in housing ..... 25 Nm  
 Closure plug in housing ..... 12 Nm  
 Return line connector in housing ..... 10 - 12 Nm



**Weights**

The weights below include the following “individual weights”:

- Pump kit with one pump element, pressure relief valve, grease filling (0.75 kg, 1.5 kg)
- Packaging (cardboard box)
- Attaching parts
- Operating instructions

**2 l - reservoir, standard design (0.75 kg)**

Pump 233 version „2A5.10“ ..... 7.1 Kg

**4 l - reservoir, standard design (1.5 kg)**

Pump 233 version „2A5.10“ ..... 9.9Kg

**8 l - reservoir, standard (1.5 kg)**

Pump 233 version „2A5.10“ ..... approx. 11.0 Kg

In the case of pump versions differing from those mentioned, add the weights of the following components to the mentioned weights.

Per pump element ..... +0.2 kg  
Per pressure relief valve ..... +0.1 kg

Connection cable with piston detector ..... 0.1 kg  
Reservoir version „Filling from top (only 2 l)\* ..... +0.15 kg  
2 l flat-type reservoir ..... +0.5 kg

**Electric Connection Diagram**

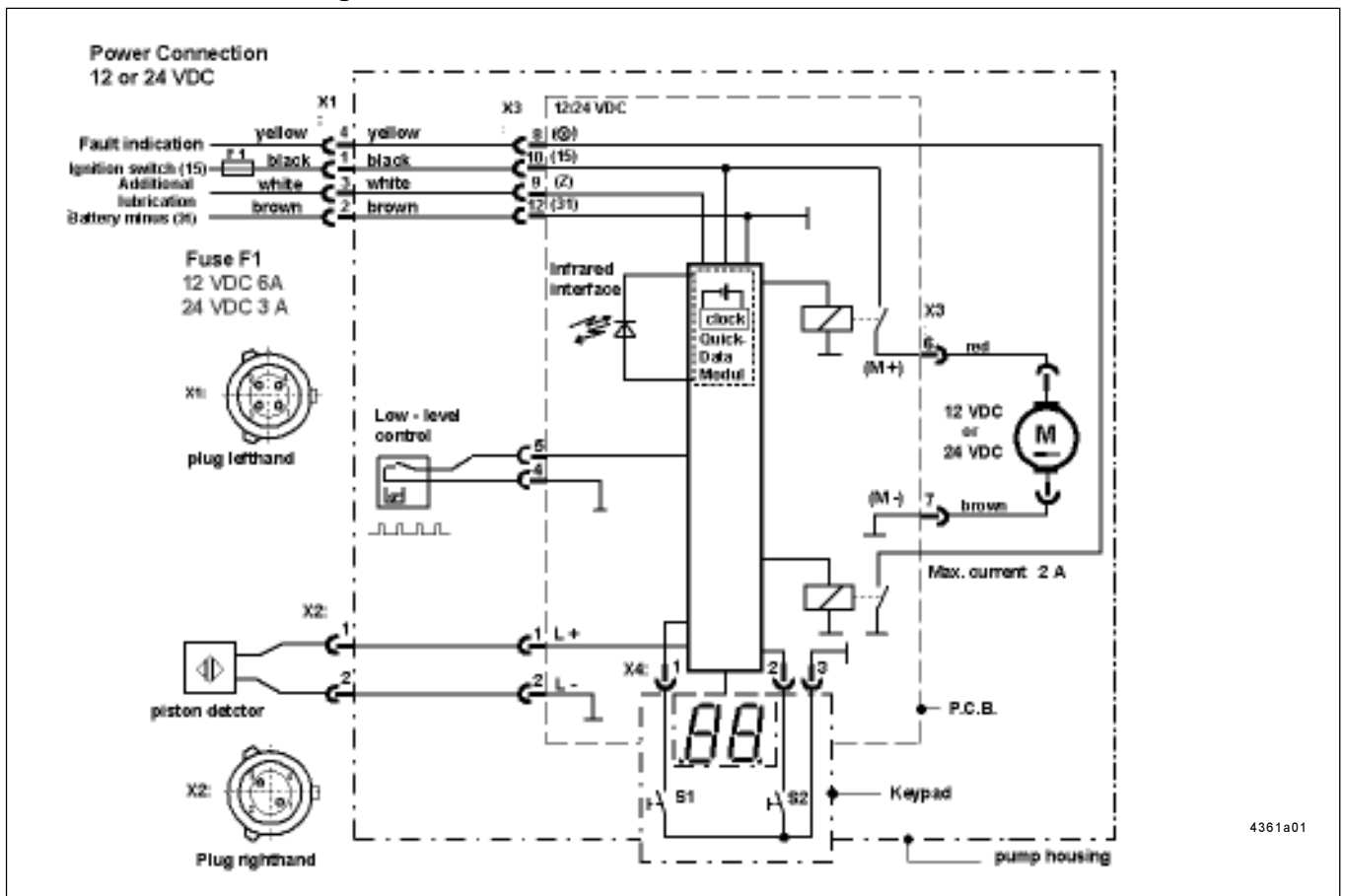

Fig. 39 - Connection diagram pump 233 with data logger

Subject to change without notice

4361a01

## Dimensions

### 2 l Reservoir

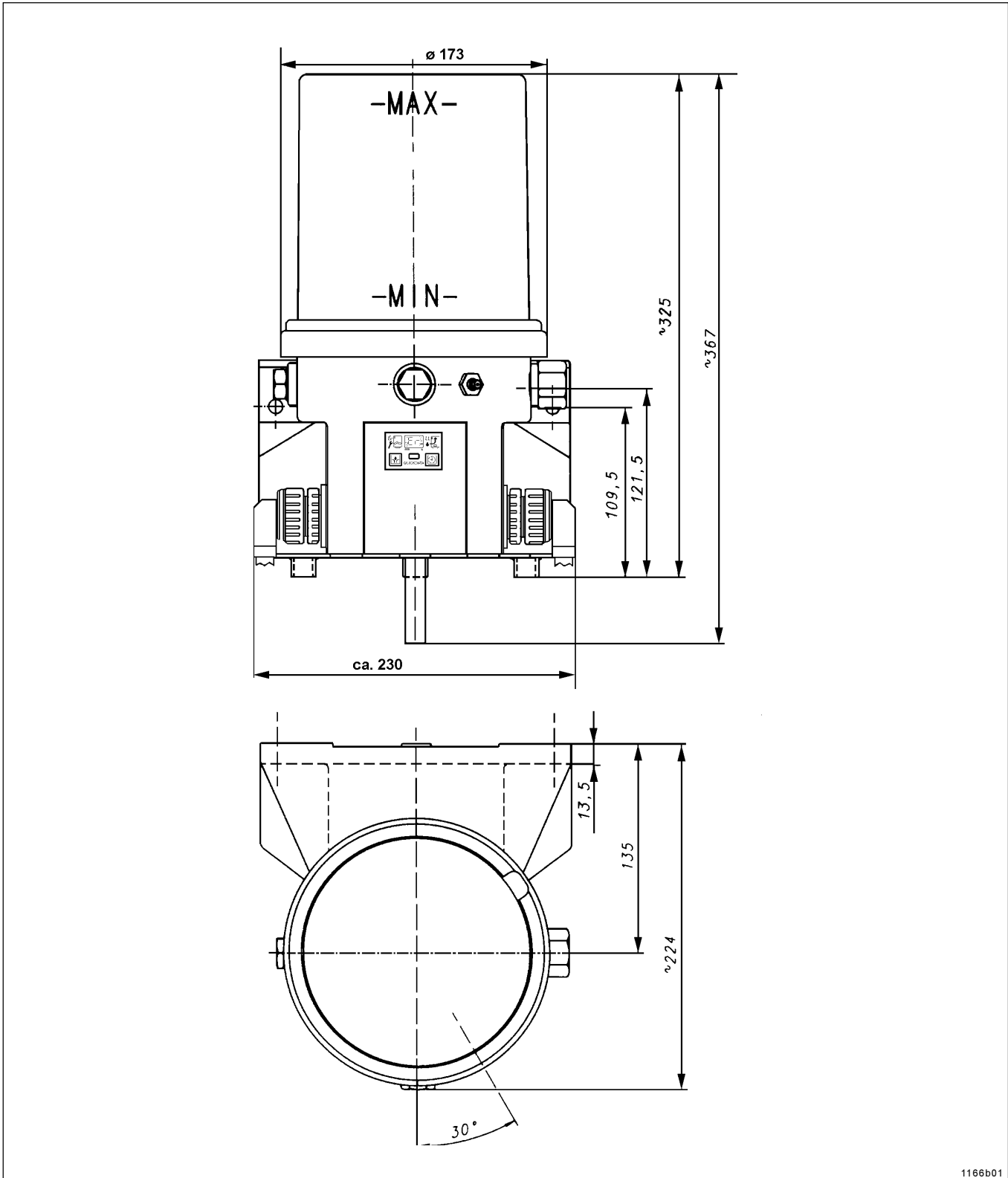

Subject to change without notice

Fig. 40 - Dimensions

1166b01

2 | Reservoir with filling from the top

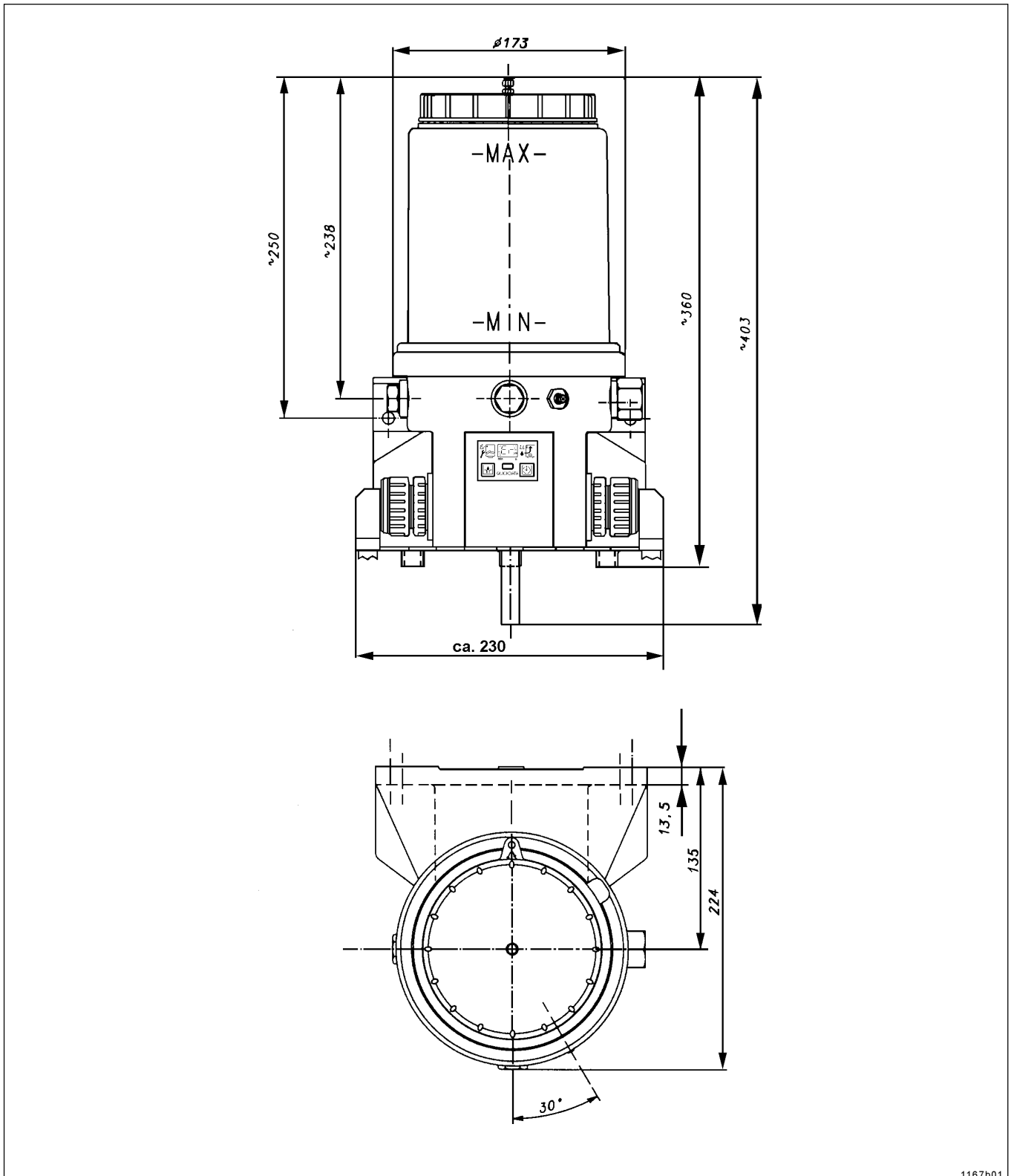
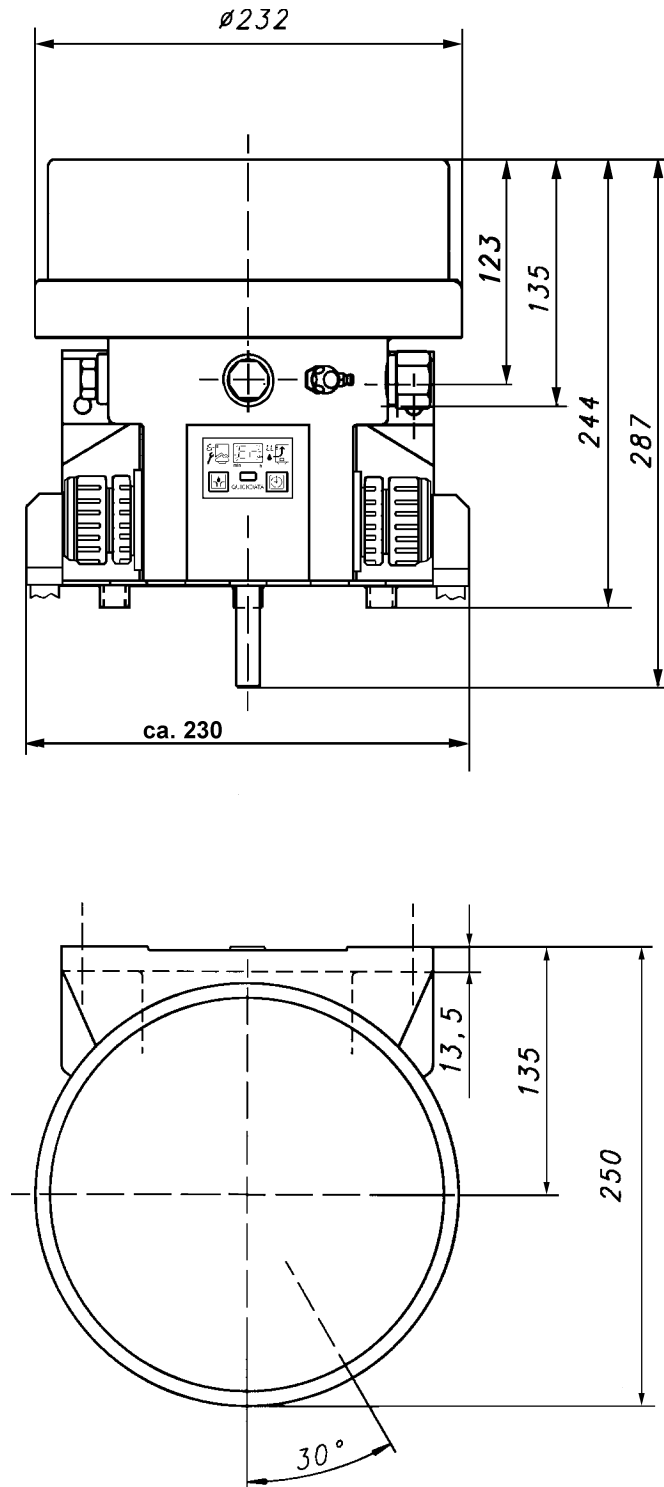

Fig. 41 - Dimensions

Subject to change without notice

1167b01

2 | Flat-type reservoir



1168b01

Fig. 42 - Dimensions

Subject to change without notice

4 | Reservoir

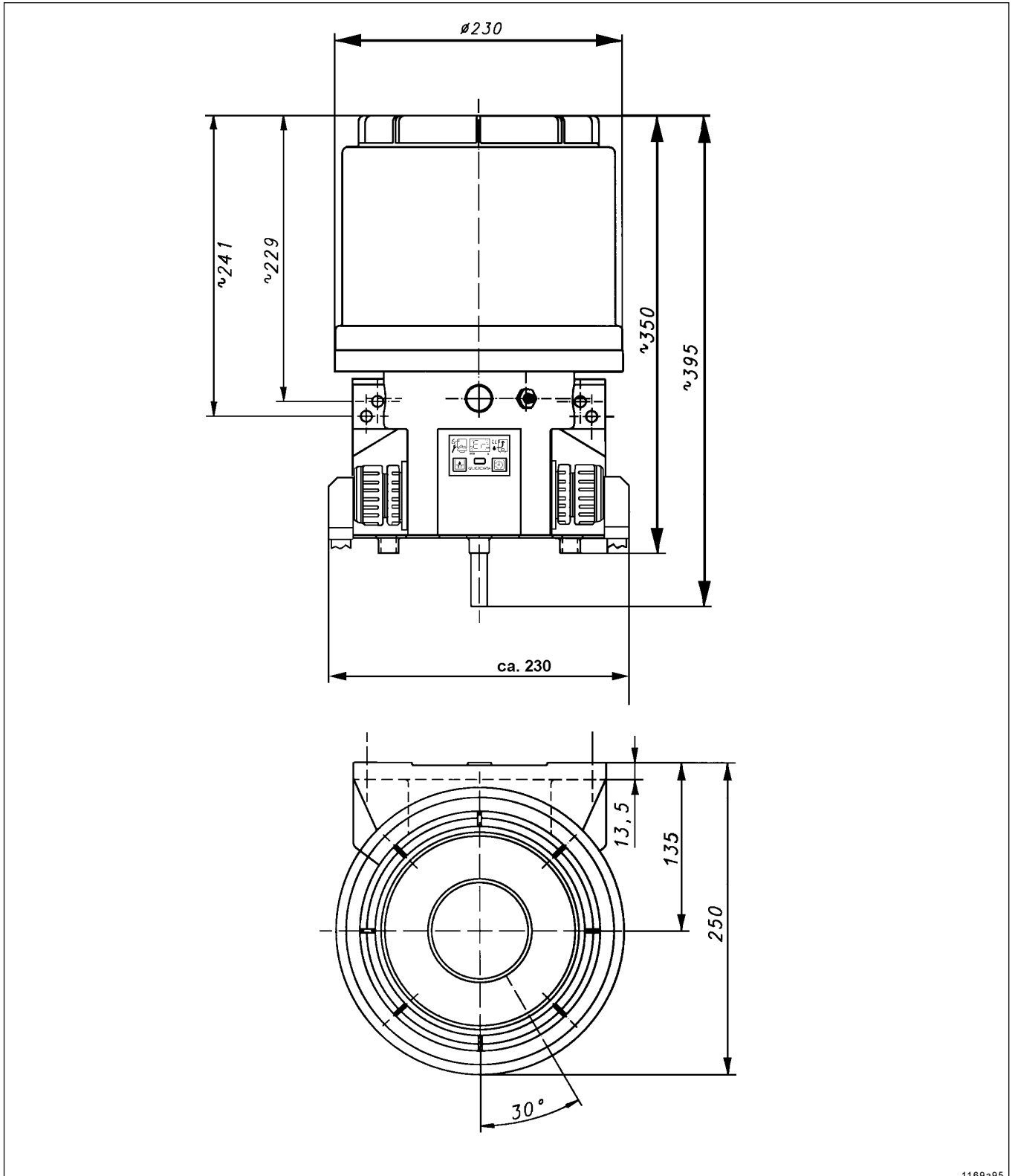

Subject to change without notice

Fig. 43 - Dimensions

1169a95

8 | Reservoir

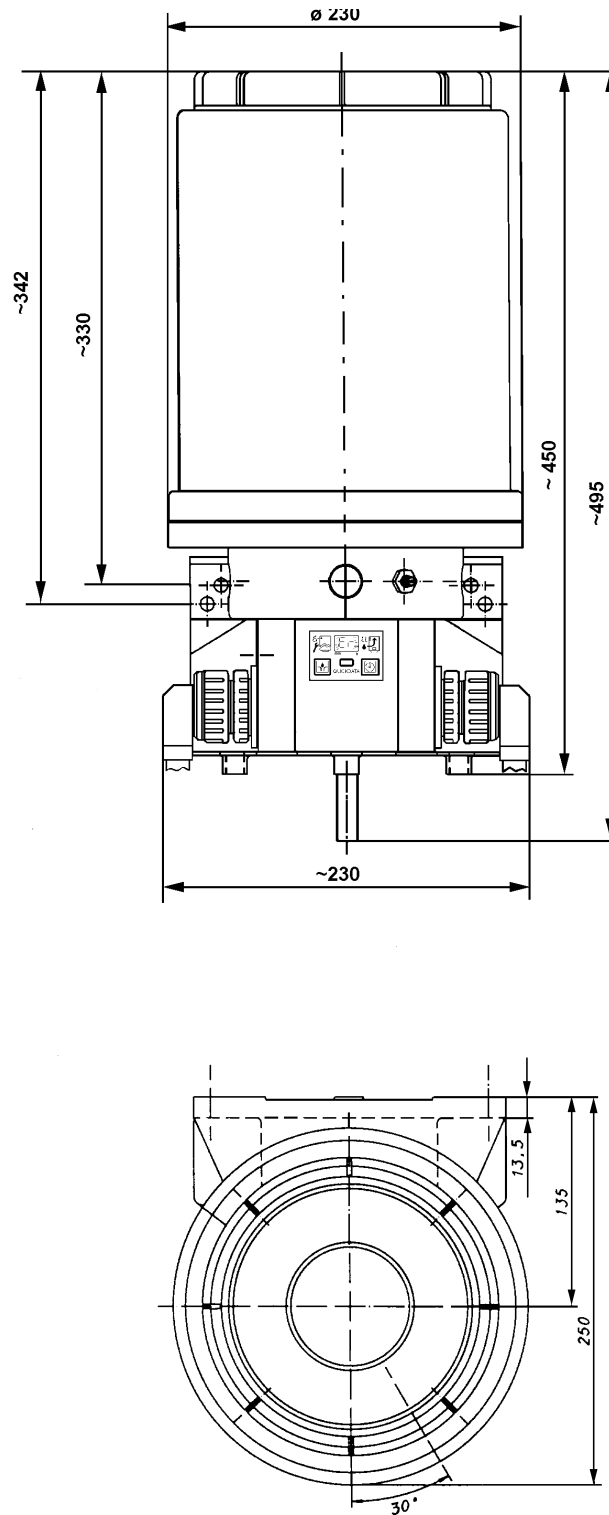

1170a95

Fig. 44 - Dimensions

Subject to change without notice

Attaching boreholes of the 2 l, 4 l, 8 l pump

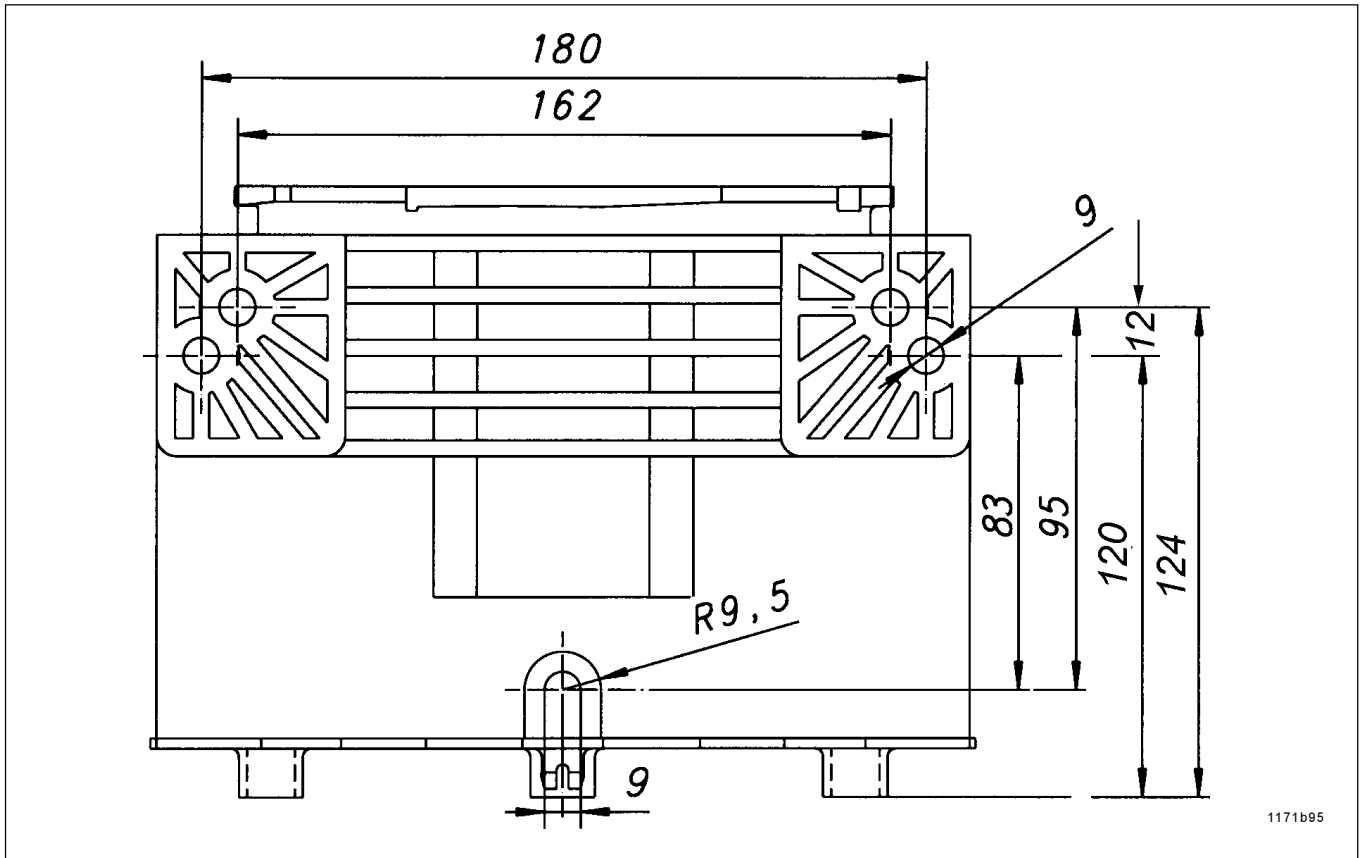

Fig. 45 - Dimensions

Note: Tighten pump models with 2 L - flat-type, 4 L - and 8 L reservoir with three fastening screws (see point R 9,5).

## Lubricants

**Important:** The manufacturer of the centralized lubrication system tests the lubricants **exclusively on their transportability in centralized lubrication systems**, not on their compatibility with other material. The lubricants tested did not cause any damage due to incompatibility on the material used by us. The **composition** of the lubricants, their **behavior** during the transport and their **compatibility** with other material are **not known to us. Lubricant recipes may change.** In case of doubts, send your request for more information to the manufacturer of the centralized lubrication system.

**The manufacturer of the centralized lubrication system can accept no liability for:**

- damages on parts of the centralized lubrication system caused by chemical or biological changes of the lubricant used.
- damages due to the use of greases that are not or only conditionally transportable in centralized lubrication systems.

**Important:** The lubricants released by us **have not been tested** with regard to their **long-term behavior**. Therefore, we can give no guaranty for damages caused by chemical reactions of the lubricant with components of the centralized lubrication system.

## Lubricants (Cont.)

The pump 233 has been designed to dispense commercial greases up to NLGI grade 2.

**Important:** Absolute cleanliness is essential when handling lubricants. Impurities will remain suspended in the lubricant and cannot settle. This will result in a blockage of the feed lines and thus damage the bearings.

**Important:** The manufacturer of the centralized lubrication system will not accept any liability for:

- damage due to the use of greases which are not or only conditionally pumpable in centralized lubrication systems
- damage caused by insufficient lubricant or irregular pump refilling.

In case of doubt ask manufacturer of central lube system.

### Tested lubricating greases for pump 233

Manufacturer	Designation	Base soap	Min. delivery temperature
AGIP	F1 Grease 24	Ca	
ARAL	Multi-purpose grease ZS 1/2	Ca/Li	-20 ° C
AUTOL	Top 2000	Ca	-10 ° C
AUTOL	Top 8000 W	Ca	-20 ° C
BP	Lubrication grease	Ca	
BP	C1 Lubrication grease	Ca	-20 ° C
CASTROL	CLS - Grease	Ca/Li	
ESSO	Cazar K2	Ca	
ESSO	High-pressure grease	Ca	
FIAT LUBRIFICANTI	Comar 2	Li	-25 ° C
FINA	Ceran LT	Ca	-20 ° C
FINA	Ceran WR2	Ca	
FUCHS	FN 745	Ca	-25 ° C
FUCHS	Renocal FN3	Ca	-20 ° C
FUCHS	Renolit HLT 2	Li	-25 ° C
KLÜBER	Centoplex 2 EP	Li	
MOBIL	Mobilgrease	Li	-30 ° C
MOLYKOTE	TTF 52	non-organic thickening agent	-30 ° C
OPTIMOL	Longtime PD 2	Li	- 20 ° C
OPTIMOL	OLIT CLS	Li/Ca	- 15 ° C
SHELL	Retinax C	Ca	
WESTFALEN	Gresalit ZSA 2	Li	-15 ° C
ZELLER & GMELIN	ZG 450	Li	
ZELLER & GMELIN	ZG 736	Li	

#### Bio-degradable greases

Manufacturer	Designation	Base soap	Min. delivery temperature
ARAL	BAB EP 2	Li/Ca	
AUTOL	Top 2000 Bio	Ca	-25 ° C
AVIA	Biogrease 1	Li	up to 0 ° C
DEA	Dolon E 2	Li	-15 ° C
FUCHS	Plantogel S2	Li/Ca	
KLÜBER	Klüberbio M32 - 82	Ca	-20 ° C

Use lubricants with solid matter additives only after having consulted the manufacturer of the system.



**Declaration by the manufacturer as defined by  
machinery directive 89/37/EEC, Annex II B**

Herewith we declare that the supplied model of

**Centralized lubrication pumpe P233**

is intended to be incorporated into machinery covered by this directive and must not be put into service until the machinery into which it is to be incorporated has been declared in conformity with the provisions of the above mentioned directive-including all modifications of this directive valid at the time of the declaration

**Applied harmonized standards in particular:**

- EN 292 - 1**            *Safety of machinery part 1*  
                          *Basic terminology, methodology*
- EN 292 - 2**            *Safety of machinery part 2*  
                          *Technical principles and specifications*
- EN 809**                *Pumps and pump units for liquids*  
                          *Safety requirements*
- EN 563**                *Safety of machinery*  
                          *Temperatures of touchable surfaces*



**Waldorf, 03.06.2002 , Dr. Ing. Z. Paluncic**



**Requesting a service page in French, Italian/Spanish language**

*Do you need a copy of this document in your language? Simply fill out the form below and fax it to our European office*

**Requesting a service page in French; part no. 2.1F-30004-A02**

**Requesting a service page in Italian/Spanish; part no. 2.1I/E-30004-A02**

**Yes, please send me the French version ; part no. 2.1F-30004-A02**

**Yes, please send me the Italian/Spanish version ; part no. 2.1I/E-30004-A02**

**Name** .....

**Company** .....

**Address** .....

**City** .....

**State** .....

**Postal Code** .....

**Country** .....

**Phone** .....

**E-mail** .....

**Send me an e-mail version I can print from my computer**

**Yes, please send me the French version ; part no. 2.1F-30004-A02.pdf**

**Yes, please send me the Italian version ; part no. 2.1I-30004-A02.pdf**

**Yes, please send me the Spanish version ; part no. 2.1E-30004-A02.pdf**

**Europe/Africa:**  
**Lincoln GmbH & Co. KG**  
**Marketing Services**  
**Heinrich - Hertz - Strasse 2- 8**  
**Germany: +49- 6227-330**  
**Fax: +49 - 6227- 33 - 125**  
**www.lincolnindustrial.de**  
**alexander\_skarsig@lincolnindustrial.de**

